



City of Merced

Request for Proposals

Data Center Uninterruptable
Power Supply Replacement

And

Data Center HVAC
Replacement

City of Merced is requesting sealed proposals from firms or individuals to supply, install, and decommission Uninterruptable Power Supplies and HVAC systems to replace the existing end of life systems.

Proposals are due no later than 2 P.M. Pacific Standard Time on December 10, 2021.

1 INTENT

The intent of this Request for Proposal (RFP) is to select a qualified supplier and award a contract for the purchase, installation, and decommission of old equipment and ongoing maintenance of a new uninterruptible power supplies and HVAC systems for the City of Merced Data Center.

2 BACKGROUND

The City of Merced is a full-service City. The City data center supports Data/Voice/Video/SCADA/LMR network communication for all City Departments.

The data center has a Liebert 15KVA UPS and Eaton 15KVA UPS that supplies power when there is a utility power outage, typically only until the on-site generator starts up. Although the UPSs has been regularly maintained they are consistently failing on the loss of street power. The UPSs are physically located in the MPOE for the City Hall facility.

The data center has two (2) Liebert 3 Ton HVAC units. These units are failing several times throughout each year.

Existing HVAC Systems and Equipment Components

The existing 3-Ton fan coils FC-1 and FC-2 are grouped together to air condition the existing Computer Room 126. The corresponding condensing units CU-1 and CU-2 are located up on the roof on existing curbs. The room is controlled by two existing thermostats associated with the AC units.

Liebert 460/3
MM036E-AHED0
FLA 13.2
WSA 16.5
OPD 20

Liebert 460/3
PFH037A-AL3
FLA 6.4
WSA 7.8
OPD 15

Existing Electrical Conditions

The existing Main Switchboard is a 277/480V, 3 phase, 4 wire board rated for 1200A. In addition to serving various panels and motor control center, it feeds a 125A automatic transfer switch (ATS) from a 70A/3P circuit breaker. There is an existing 40kW/50kVA generator with a 70A/3P breaker feeding the emergency power line side of the ATS. The ATS feeds emergency power panel EP. Refer to electrical sketches included for additional information.

The two existing UPSs are located in existing pump room #113.

1. Liebert UPS (model #NX-15)
 - a. 15kVA
 - b. Input voltage: 480V, 3 phase
 - c. Output voltage: 480V, 3 phase
2. Powerware UPS (model #9355-15)
 - a. 15kVA

- b. Input voltage: 208V, 3 phase
- c. Output voltage: 120/208V, 3 phase

The Liebert UPS is fed from an existing 30A/3P circuit breaker in panel EP. The Powerware UPS is fed from an existing 50A/3P circuit breaker in panel EP via an existing 45 kVA transformer and a manual bypass switch panel ("panel Bypass").

The existing fan coils are fed from existing panel EP (277/480V, 3 phase, 4 wire, 125A) via one existing 20A/3P circuit breaker. The existing condensing units are fed from existing panel EP via one existing 40A/3P circuit breaker.

Attachments / Additional detail

3 SCOPE OF WORK

- a) City of Merced is seeking proposals from qualified vendors with demonstrated experience. Joint proposals will not be accepted. If a firm intends to have labor, software, services or equipment provided by other solution providers, it will be mandatory for the firm submitting the proposal to act as the prime consultant for all service/equipment delivery as specified in this RFP. The proposing firm shall be considered the sole point of contact regarding contractual stipulations.
- b) City of Merced proposes to engage the selected proposer to provide the hardware and labor necessary to install two (2) new UPS's and two new (2) HVACs as detailed in the ESSENTIAL COMPONENTS AND FEATURES section.
- c) The Proposer will be expected to uninstall the existing UPS's and HVAC systems and install the two (2) new UPS's and two (2) HVAC systems while minimizing impact to the City and its users. This will involve careful planning with City staff of any power and HVAC disconnects.
- d) The proposer shall provide documentation and training to staff on normal operation of systems.
- e) The proposer shall obtain, at proposer expense, all permits required by the City of Merced.
- f) The proposer shall create and provide, at proposer expense, all electrical and mechanical drawing required to obtain permits. This includes any C-10, P.E, or similar stamps that may be required on drawings for permits.
- g) For the project to be considered complete, all items in the SYSTEMS ACCEPTANCE CRITERIA will be met.
- h) All labor must be at prevailing wage rate. The project must be registered with CA DIR.
- i) The proposer shall install all needed cabling, conduit, water lines, drainage, and ducting required for the proposed solution. All infrastructures must conform to City of Merced and state electrical and mechanical requirements.
- j) Proposer shall decommission and haul away old UPS'S system. Proposer shall certify equipment will be disposed via a state of California approved e-waste method/vendor.
- k) Proposer shall decommission, remove and haul away all components of old HVAC systems. Proposer shall not be required to remove nonvisible conduit, cables, or drain lines.

- l) Proposer shall ensure the proposed HVAC systems will not raise the ambient noise level of the office environment (not including the data center itself) where HVAC equipment will be located, including above any dropped ceilings. If the HVAC does raise the ambient noise level the proposer shall be required to mitigate the increased noise at the proposer expense. The current noise level is documented below.



- m) The Proposer shall be required to obtain a City of Merced Business License.
- n) The proposer shall ensure the UPSs are integrated into the existing transfer switch/bypass switch or replaced with new transfer switch between street power and generator.
- o) The proposer will ensure that all work performed will not cause a discharge of the City of Merced Data Center Halon fire suppression system. The proposed shall bear all cost to repair/replace and recertify the Halon system if a discharge does occur.
- p) The mechanical Basis of Design scope of work generally includes:

Mechanical

- Re-use existing exhaust fan, supply, return and exhaust air main ductwork and terminal units as-is to serve the rooms ventilation.
- Route new metal ducts to connect to existing ceiling supply diffusers and return grilles.

Plumbing

- Re-use existing condensate drain piping
- Modify existing condensate to accommodate the project work.
- Route the new refrigerant lines serving the condensing units up on the roof

4 ESSENTIAL COMPONENTS AND FEATURES OF UPS SYSTEMS

The proposed solution must exhibit the following essential characteristics:

- a) The two (2) UPS'S must be by the same manufacturer. NOTE: The UPS and HVAC systems does not need to be by the same manufacturer.
- b) The UPS's must be competitively priced.
- c) An important characteristic of the UPS will be its reliability. The successful Proposer is expected to provide a solution with high levels of reliability. Please provide documentation from manufacturer to document reliability of system.
- d) The proposed UPS's must be new equipment, not used or refurbished.
- e) The proposed UPS's must be at least 15KVA each.
- f) The proposed UPS's must have a power factor of .96 or greater.
- g) The UPS's must provide 15 minutes or more of run time based on 60% load.
- h) The installation should conform to local electrical codes and meet industry standards.
- i) The UPS's must be wired into existing bypass panel.
- j) The UPS's will be fed from panel EP. It is assumed that the existing breakers and feeders can be reused for both UPS's
- k) It is assumed that existing panel EP and the existing generator shall be able to accommodate the new increase in load. Per facility snapshot of the load on panel EP, the existing load is approximately 38 Amps (31.58 kVA) on the panel. Contractor shall confirm existing load and verify that the added load can be accommodated by panel EP and the existing generator.
- l) The proposed systems should include network monitoring, preferably via a web browser and SNMP. It should include the ability to automatically send email alerts.
- m) Both UPS's must fit into a total footprint of 96 inches by 48 inches.
- n) The proposer should evaluate the site access and delivery options and propose systems that can be delivered and installed without requiring any modifications to building access. The City of Merced has no loading dock.
- o) Any additional software or hardware that is not listed in this RFP but is required for completion of the proposed solution must be clearly specified in the proposer's RFP response.

5 ESSENTIAL COMPONENTS AND FEATURES OF HVAC SYSTEMS

The proposed solution must exhibit the following essential characteristics:

- a) The two HVAC systems must be by the same manufacturer. NOTE: The UPS and HVAC systems do not need to be by the same manufacturer.
- b) The two HVAC systems must be competitively priced.
- c) An important characteristic of the HVAC systems will be its reliability. The successful Proposer is expected to provide a solution with high levels of reliability. Please provide documentation from manufacturer to document reliability of system.
- d) The proposed HVAC systems must be new, not used, or refurbished.
- e) The proposed HVAC systems shall be 5 Tons Each.
- f) The existing circuit in panel EP feeding the existing fan coil units FC-1 and FC-2 shall be reutilized to feed the new fan coil units (460V, 3 phase, 3.2 FLA). Provide disconnect at each unit as required. Verify conductors to the units are a minimum 3 #12 and 1 #12 'G'.
- g) The existing circuit in panel EP feeding the existing condensing units CU-1 and CU-2 shall be demolished. The new condensing units (460V, 3 phase, 12.6 FLA) will require new breakers in panel EP and new feeders up to the new units. For each unit, provide a new 25A/3P circuit breaker in the existing space and (1) 1" conduit with 3 #10 and 1 #10 'G'. Provide new 30A fused disconnect with each condensing unit.
- h) The proposer should evaluate the site access and delivery options and propose systems that can be delivered and installed without requiring any modifications to building access. The City of Merced has no loading dock.
- i) Any software or hardware that is not included in the proposal, but is required for completion of the proposed solution must be clearly specified in the proposal.

6 CODES, STANDARDS, AND REFERENCES

The Basis of Design narrative is based on the 2019 version of Title 24, including: all code and design standards must be followed.

- o 2019 California Building Code (CBC)
- o 2019 California Mechanical Code (CMC)
- o 2019 California Plumbing Code (CPC)

The Basis of Design narrative considers information obtained from the staff, a visit to the site, coordination with other consultants and record drawings.

7 DELIVERABLES

UPS's with all required components
HVAC's with all required components
Installed and operational UPS's
Installed and operational HVAC's
Electricals/mechanical plans that meet Permit requirements stamped Licenses holder.
Manuals or documentation for all components of the system
Completion of acceptance test plan
2 hour training on system operations for UPS
2 hour training on system operations for HVAC

The system shall include all items listed in the Scope of Work and Essential Components and features sections.

Any items that are required to complete the system, but will not be provided by the proposer must be specified by the proposer in the RFP response.

8 OPERATIONS, MAINTENANCE AND SUPPORT

The Solution Provider is expected to have plans offering how they (or another vendor) will maintain and support the UPS for 3 years. Solution Provider should address the following aspects:

- **Customer Support Structure:** Overview of the customer support structure and procedures. Include the process from the viewpoint of the on-site end-user support personnel.
 - **Customer Assistance:** Customer helpdesk support availability (during normal business hours of the Solution/Hardware Provider).
 - **Onsite Maintenance and Support:** Options available and responsiveness in terms of time (i.e. 24/7, 4-hr windows, next business day, etc.).
 - **Escalation Process**
 - **Service Level Agreement**
- **3 Year Warranty:** The vendor will indicate the warranty period for both system hardware and software components. The vendor will also describe the different maintenance/support plans available after the 3-year warranty period. Please provide cost details on included and extended warranty/maintenance plans. Ensure that all appropriate costs are included in the Price Proposal specifically on-going maintenance costs.
- **System Failures:** Process for dealing with System failures. Plans should include a matrix or flow chart of possible system failures and what troubleshooting steps may be taken by City of Merced staff before contacting the proposer's support staff.

9 SYSTEM ACCEPTANCE CRITERIA

After installing the system hardware and software and performing appropriate diagnostic tests, the Solution Provider will certify that hardware and software is functioning correctly. Acceptance testing shall demonstrate system features, functions and failure modes as described in the Essential Components and Features section. City of Merced may request specific demonstrations of the hardware-software readiness.

Upon completion of field installation of the system and training of personnel, the Proposer will certify that the system is ready for acceptance. The Proposer will be required to demonstrate all system functions to City of Merced satisfaction. The Proposer will immediately correct any problems found during this demonstration. City of Merced will verify the corrections have been made and accept the system.

10 SELECTION PROCESS AND AWARD

City of Merced will form a team to review all proposals. Once a proposal is selected for award it will be taken before the City of Merced Council for Approval and adoption.

PROPOSAL EVALUATION

Additionally, the criteria upon which the evaluation of the proposals will be based include, but are not limited to, the following:

- a) Total costs
- b) Completeness of the proposal
- c) Quality and depth of references
- d) Vendor compliance with state and federal legislative mandates and standards
- e) Level of service and responsiveness that the Solution Provider commits to providing City of Merced
- f) Experience and technical expertise of firm's staff as proposed
- g) Economic feasibility and justification of all costs
- h) Solution Provider's willingness and ability to sign City of Merced Contracts with no Redlines.
- i) Quality and extent of Solution Provider's documentation provided

PROPOSER QUALIFICATIONS, EXPERIENCE, AND SELECTION CRITERIA

Proposers will be evaluated based upon any one or all of the following general criteria:

- a) General experience of the Proposer.
- b) Record of the Proposer in successfully replacing a similarly sized UPS / HVAC.
- c) Understanding of the Proposed project.
- d) Qualifications and years of experience of the proposed equipment providers.
- e) Financial stability and resources of the Proposer
- f) Cost of equipment/software/support and maintenance
- g) Compliance and responsiveness to the conditions and needs expressed in the RFP.
- h) Documented proof of successful implementation in technically related projects.
- i) Sample timelines based on prior project experience.

11 GENERAL INSTRUCTIONS

PROCUREMENT SCHEDULE

Pre-Bid Meeting / Site Visit	December 1, 2021 (10:00am)
Written Questions about the RFP due	December 3, 2021
Responses to Questions Posted	December 6, 2021
Proposals are due	December 10, 2021 (2:00pm)
Selected Proposer notified	December 17, 2021
Contract approved by City of Merced	TBD

The schedule for installation shall be established after award by the City Council

The Pre-Bid Meeting / Site Visit is optional, highly encouraged, for all proposers. Any questions asked/answer during site visit are not binding and not part of the RFP requirements. All questions must be submitted in writing by the procurement schedule listed above.

PROPOSAL SUBMITTAL

Firms having the qualifications and experience to perform the necessary services may submit proposals to:

City of Merced
Michael R. Beltran II, PE
City Engineer
678 W 18th Street
Merced, CA 95340

Please submit (3) three printed copies of your proposal.

Proposals may also be submitted (in person only) to Michael Beltran located at the same address **no later than 2 P.M. Pacific Standard Time on December 10, 2021**. Failure to meet the deadline shall result in disqualification of the proposal without review. Submittals shall include one electronic and two hard copy of the following:

- a) Brief and concise statements of general background, staffing, and capabilities of the Solution Provider.
- b) Detailed documentation of recent experience of installing a similarly sized UPS.
- c) The name of the person within the Solution Provider assigned to work on this project, a statement of that person's availability, and a list of other members who may also become involved on the project.
- d) A section that describes how the solution will meet each of the items in the sections "ESSENTIAL COMPONENTS AND FEATURES", "DELIVERABLES", and "OPERATIONS, MAINTENANCE AND SUPPORT".
- e) A cover letter and brochures may be submitted in addition to the proposal.

PRICING SCHEDULE

Data Center Uninterruptable Power Supply Replacement and Data Center HVAC Replacement

- Pricing proposal shall be the maximum fee to be charged for the proposed services, hardware and software, and labor.
- Pricing shall be broken down by task. Proposal shall list projected man hours by task required to complete the work as defined in Scope of Work along with the hourly billing rates for the various levels and staff who will be assigned to the project.
- Pricing proposal shall also cost summary as listed below.
- Proposal shall be signed.

Cost Summary

Cost	Total
Equipment	
Documentation and training	
Support/Maintenance	
Installation / Engineering	
MISC /other	
Grand Total	

The undersigned acknowledges receipt of the referenced RFP and/or Addenda and offers and agrees to furnish the articles and/or services specified on behalf of the proposer indicated below, in accordance with the specifications, terms and conditions of this RFP and Proposal Acknowledgement, for the pricing indicated on the Pricing Schedule.

Company Name (Proposer):	
By (Person Submitting Proposal): (Print)	
By (Person Submitting Proposal): (Signature)	
Title of Person Submitting Proposal	
Business Address (City/State/Zip):	
Email Address:	
Telephone Number:	
Date:	

REFERENCES

All proposers must provide a list of three (3) current or former clients in the area provided below, identifying prior experience with the same type of project similar in size, application, and scope services requested by the City under Scope of Work. References shall have similar projects and requirements to those outlined in these specifications, terms and conditions. Proposer's failing to provide references shall be deemed unacceptable.

Company Name:
Address:
City, State, Zip Code:
Contact Person:
Email Address:
Telephone Number:
Type of Business:
Date of Installation:
Contract Value

Company Name:
Address:
City, State, Zip Code:
Contact Person:
Email Address:
Telephone Number:
Type of Business:
Date of Installation:
Contract Value

Company Name:
Address:
City, State, Zip Code:
Contact Person:
Email Address:
Telephone Number:
Type of Business:
Date of Installation:
Contract Value

The City may contact some or all of the references provided in order to determine the Proposers' performance record on services similar to that described in this proposal. The City reserves the right to contact references other than those provided in the response and to use the information gained from them in the award process.

EXCEPTIONS, CLARIFICATIONS, AMENDMENTS

Exceptions, Clarifications, Amendments

List requests for proposal clarifications and exceptions below, if any, sign and submit with your proposal response.

EXAMINATION OF DOCUMENTS

Proposers shall examine carefully all documents and data provided. No pleas of ignorance of the requirements or of the documents will be accepted as a basis for any claim whatsoever for extra compensation.

COST OF PREPARATION OF PROPOSAL

The City shall not pay costs incurred in the proposal preparation, printing, demonstration, or negotiating process. All costs shall be borne by the proposer.

CONTACT WITH CITY OR EMPLOYEES

In order to ensure fair and objective evaluation, all questions related to this RFP should be emailed directly to J.R. Wright at wrightj@cityofmerced.org. Questions and responses will be made available to all interested parties via post to the City of Merced website.

12 GENERAL TERMS AND CONDITIONS

ORDER OF PRECEDENCE

Incorporated by reference into the contract which is to be entered into by City of Merced and the successful Proposer pursuant to this RFP shall be: (1) all of the information presented in or with this RFP and the Proposer's response thereto; and (2) all written communications between City of Merced and the successful Proposer after the date of the RFP. These documents shall include but not be limited to the following, in order of precedence:

- A. Contract, including negotiated technical points
- B. Written Clarifications (Formal Requests for Clarification and responses)
- C. Compliance Statements (Point-by-Point Response to RFP)
- D. RFP Addenda
- E. RFP
- F. Proposal amendment
- G. Proposal
- H. Vendor terms and conditions included in Proposal

SALES TAX

The purchaser, City of Merced, is not exempt from California state sales and use taxes. The Proposal shall include all taxes and fees applicable. The Sales Tax Rate for the City of Merced is currently 8.25%. The tax rate should be verified by Proposer prior to submitting the Price Proposal.

NO ASSIGNMENT

Assignment by the successful Proposer to any third party of any contract based on this RFP or any monies due shall be absolutely prohibited and will not be recognized by City of Merced unless approved by the representative of City of Merced in writing. Approval will not be unreasonably withheld.

NON-DISCRIMINATION IN EMPLOYMENT

By signing this Proposal, the Proposer certifies that it does not and will not during the performance of this contract knowingly employ illegal alien workers or otherwise violate the provisions of the Federal Immigration Reform and Control Act of 1986.

During the performance of this contract, the Proposer shall be governed by all applicable state and federal regulations, and agrees as follows:

- a) The Proposer will not discriminate against any employee or applicant for employment because of race, religion, color, sex or national origin. The Proposer agrees to post in conspicuous places, available to employees and applicants for employment, notices setting forth the provisions of this non-discrimination clause.
- b) The Proposer, in all solicitations or advertisements for employees placed by or on behalf of the Proposer, will state that such subcontractor is an equal opportunity employer.
- c) Notices, advertisements and solicitations placed in accordance with federal law, rule or regulation shall be deemed sufficient for the purpose of meeting the requirements of this section.
- d) The City also encourages the good faith effort by contractors, suppliers and vendors to sub-contract and procure from small minority, disabled-owned and women contractors, suppliers and vendors.

FORCE MAJEURE

Neither party will be liable to the other for any failure or delay in rendering performance arising out of causes beyond its reasonable control and without its fault or negligence. Such causes may include, but are not limited to acts of God or the public enemy, fires, floods, strikes, freight embargoes and unusually severe weather; but the failure or delay must be beyond reasonable control and without fault or negligence. If the Proposer's failure to perform is caused by the default of a subcontractor, and if such default arises out of causes beyond the reasonable control of both the Proposer and subcontractor, and without the fault or negligence of either of them, the Proposer shall not be liable for any excess costs for failure to perform, unless the equipment or services to be furnished by the subcontractor were obtainable from other sources in sufficient time to permit the Proposer to meet the required delivery schedule. Dates or time of performance will be extended to the extent of delays excused by this section, provided that the party whose performance is affected notifies the other promptly of the existence and nature of such delay.

Please note : Epidemics and quarantine restrictions are not a force Majeure events due to COVID-19. All considerations will be made to make reasonable accommodation due to COVID-19.

CONTRACTOR REGISTRATION

The Proposer and all firms performing work on behalf of the Proposer shall have all necessary federal, state and local licenses, and remain licensed through the completion of the work.

CONTRACTOR RESPONSIBILITIES

The Proposer shall be considered the Prime Contractor and shall assume total responsibility for delivery, installation, acceptance, and warranty of all hardware, software, and engineering and support services offered in the Proposal, whether or not the Proposer is the manufacturer, producer, author or supplier of them.

The Proposer shall be the sole point of contact with regard to all contractual matters, including the performance, service, and payment of any and all charges resulting from the lease and installation of the entire system configuration, and all other services performed. Failure to meet these obligations shall result in the cancellation of any contracts.

PROJECT MANAGER

A single person shall be designated by the Proposer as Project Manager to be the primary source of contact between City of Merced and the Proposer. The Project Manager, as a member of the Project Team, shall bear full responsibility for supervising and coordinating the installation of the proposed system.

Within 30 working days after execution of the contract, the Proposer shall advise City of Merced of the name, address and office and home telephone numbers of the Proposer's designated Project Manager.

Any changes in the Proposer's designated Project Manager shall be made only with prior written approval by City of Merced.

SYSTEM RESPONSIBILITY

The Proposer shall be responsible for verifying the completeness and suitability of all work or equipment proposed for this system. The Proposer shall provide any additional equipment or labor required in order to meet these specifications, without claim for additional payment, it being understood that a complete operating system is required.

The Proposer shall be responsible for designing, furnishing, and installing all required interfaces with existing systems and equipment, as well as such interfaces that might be specified in the system specification, unless such interfaces are specifically excluded or ascribed to others in this specification. The Proposer shall be obligated to provide a system that meets all guarantees in the Proposal for the price contained therein.

PERMITS, PERMISSIONS, AND SERVICES

The Proposer shall be responsible for obtaining any local, state, or federal permits, licenses and approvals necessary to implement this project.

All fees and costs associated with facility permits, permissions, and services shall be the responsibility of the Proposer without cost to City of Merced unless specifically noted elsewhere.

QUALIFICATION OF PERSONNEL

Personnel shall have the appropriate training, experience, and certifications to complete assigned tasks. The Proposer shall be responsible for oversight of all personnel including subcontractors.

COORDINATION WITH CITY OF MERCED OPERATIONS

The Proposer shall coordinate all work with City of Merced operating and scheduling requirements. This may require the Proposer to perform specific elements of the work (such as cutovers, installation of non-fixed equipment, etc.) during periods outside City of Merced peak working hours.

PROPERTY DAMAGE

The Proposer shall be responsible for any loss or damage to property caused by his operations or personnel. Damages will be settled with the owner of the property by the Proposer in the company of an agent of City of Merced. The Proposer shall submit a signed damage release for all sites concerned within 20 days after cutover.

SYSTEM USE BEFORE ACCEPTANCE

City of Merced is planning to accept the new system in total. Acceptance shall be on a system basis only. There shall be no "conditional acceptance" of any portion of the system.

It may become necessary however, because of unplanned events, for City of Merced to use a part or all of the system or a subsystem. Such use shall not constitute acceptance unless it continues for 45 consecutive days. The Proposer will be entitled to seek relief from any damages for delays which result from such unplanned use of the system or subsystems.

ACCEPTANCE DEFAULT

Should specific devices or subsystems fail to meet specifications during the acceptance tests, City of Merced may, at its option, elect one of the following procedures:

- A. The Proposer shall repair the equipment and retest that device or subsystem later in the test sequence.
- B. The Proposer shall retest the device or subsystem at a later date and submit the results to City of Merced for approval.

In the event that devices, subsystems, or systems fail to meet specifications upon retest, or in the event that multiple devices or subsystems fail during any individual test sequence, City of Merced may terminate the test sequence for rescheduling at a later date.

In the event that the Proposer has provided notice that work is complete and the system or subsystem is available for inspection or acceptance testing, and then at the appointed hour and place for inspection or testing, it is determined that the system or subsystem is not complete or ready for testing, and the Proposer has not provided five days notice of change in schedule, then the system or subsystem will be considered to be in "Acceptance Default".

In the event of termination and rescheduling of any test for failure to meet specifications, or of re-inspection or re-testing of a system that has been placed in "Acceptance Default", any additional costs due to the rescheduling shall be borne by the Proposer.

CHANGE ORDERS

A separate change request must be completed for each requested change. Change orders shall not become binding until agreed to by the Project Team and signed by City of Merced and the Proposer. The change order will then be incorporated as an official change to the project.

PAYMENT SCHEDULE

Partial payment will be made to the successful Proposer based on when the following milestones are met.

- | | |
|-------------------------------|-----|
| 1. Contract is fully executed | 10% |
| 2. UPS Permits issued | 5% |
| 3. UPS installed | 20% |
| 4. HVAC Permits issued | 5% |
| 5. HVAC Installed | 30% |
| 6. 30 day acceptance complete | 30% |

Any payment terms shall be NET45.

This drawing is the property of Golden Valley Engineering & Surveying, Inc. and shall not be reproduced, stored in a retrieval system, or transmitted in any form or by any means, electronic, mechanical, photocopying, recording, or by any information storage and retrieval system, without the prior written permission of Golden Valley Engineering & Surveying, Inc. © 2011 Golden Valley Engineering & Surveying, Inc.

REVISIONS:

GOLDEN VALLEY
ENGINEERING & SURVEYING
405 W. 18th Street • P.O. Box 349 • Merced, CA 95340
Phone (209) 722-3200 • Fax (209) 722-3254

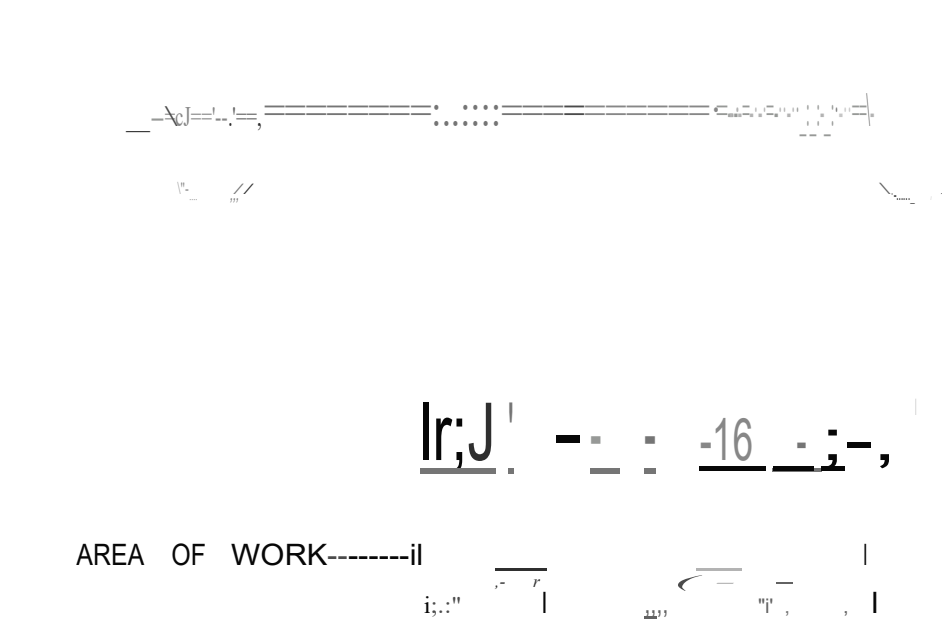
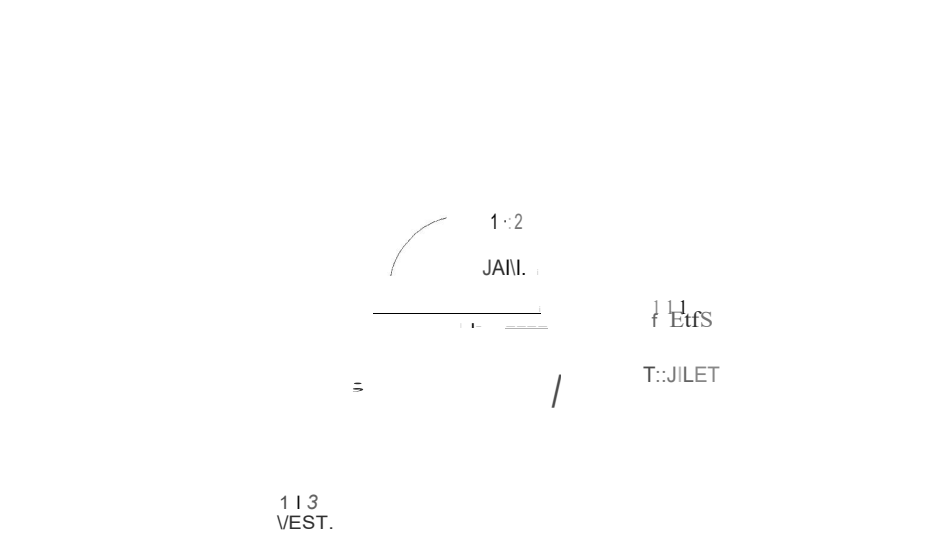
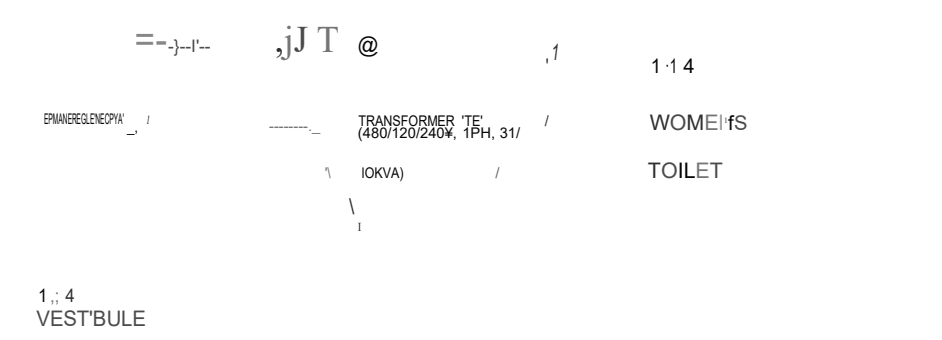
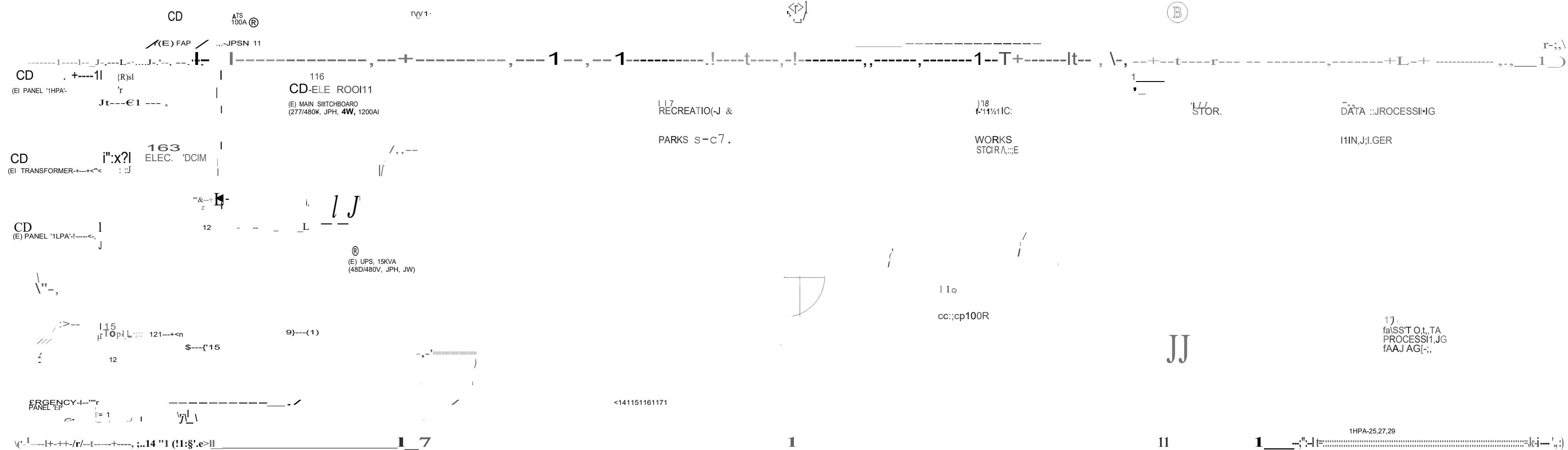

- ELECTRICAL PLAN NOTES:**
- (I) EXISTING TO REMAIN.
 - (G) EXISTING UPS TO REMAIN AND TO BE RECONNECTED. REMOVE EXISTING FEEDER WIRING. EXISTING FEEDER CONDUIT SHALL BE ABANDONED IN PLACE. TURN OFF EXISTING FEEDER BREAKER AND LABEL "SPARE".
 - (J) EXISTING PDC TO REMAIN.
 - CD EXISTING FEEDER FROM EXISTING UPS TO EXISTING POC TO REMAIN.
 - (K) EXISTING AC UNIT FEEDER FROM EXISTING PANEL TO REMAIN AND TO BE RECONNECTED.
 - (L) EXISTING FIRE ALARM PULL STATION TO REMAIN.
 - (M) EXISTING EMG PUSH BUTTONS AND WIRING TO REMAIN.
 - (N) INTERCEPT EXISTING FEEDER FOR EXISTING AC UNIT AT EXISTING PANEL, WITH 4S JUNCTION BOX. RUN NEW 1" C 111TH J#10 + 1#10 GROUND FROM NEW EMG PANEL "EP" TO RECONNECT EXISTING FEEDER. RUN NEW 1" C 111TH 318 + 1#10 GROUND FROM NEW EMG PANEL "EP" TO RECONNECT EXISTING UPS.
 - (O) INSTALL NEW TRANSFORMER ON EXISTING SLAB PER DETAIL ON E2. VERIFY LOCATION WITH OWNER PRIOR TO ROUGH-IN.
 - (P) VERIFY LOCATION OF NEW PANELS AND ATS WITH OWNER PRIOR TO ROUGH-IN.
 - (Q) REFER TO LINE DIAGRAM ON E2 FOR FEEDER CONNECTION.
 - PROVIDE RECEPTACLES, RED FINISH FOR EMERGENCY, SURFACE ON EXISTING WALL AS INDICATED. RUN 1/2" C 111TH 2#12 + 1#12 GROUND TO NEW PANEL.
 - "EPA", CONNECT TO CIRCUIT #1.
 - (R) 1" C - 4#10 + 1#10 GROUND.
 - (S) 1-1/4" C WITH 414 + 1JIB GROUND FOR POC/IR AND 2#12 FOR GENERATOR START/STOP CONTROL.
 - (T) 1" C - 2#12 + 1#12 GROUND FOR EMG LIGHTING CIRCUIT.
 - (U) RUN NEW CONDUITS IN ATTICS. VERIFY ROUTING IN FIELD.
 - (V) PULL BOX IN ATTIC SHALL BE 12" X 18" X 4". SECURE TO BUILDING STRUCTURE. VERIFY LOCATION IN FIELD AND AS DIRECTED BY OWNER.
 - (W) PROVIDE RECEPTACLES, RED FINISH FOR EMERGENCY, IN EXISTING WALL AS INDICATED. RUN 1/2" C WITH 2#12 + 1#12 GROUND TO ATTIC PULL BOX. CONNECT TO CIRCUIT 2. CUT AND PATCH EXISTING WALL FOR NEW OUTLET BOXES AND CONDUITS.
 - EXISTING LIGHTS IN COMPUTER ROOM TO REMAIN. DISCONNECT WIRING FROM EXISTING NORMAL LIGHTING CIRCUIT FROM PANEL "HPA". RUN 1/2" C 111TH 2#12 + 1#12 GROUND TO ATTIC PULL BOX TO RECONNECT LIGHTS ON EMG CIRCUIT. EXISTING SWITCHING IN ROOM TO REMAIN.
 - (X) PROVIDE GENERATOR REMOTE ANNUNCIATOR PANEL PER SPECIFICATION. FLUSH MOUNT IN WALL CUT AND PATCH WALL FOR PANEL AND CONDUIT. VERIFY LOCATION WITH OWNER.
 - (Y) 1-1/4" C - 4#1 + 1,118 GROUND.
 - (Z) 1" C - 3#10 + 1#10 GROUND.
 - PROVIDE WATERPROOF LB OUT OF EXTERIOR WALL. PATCH AND SEAL AROUND CONDUIT PENETRATION. CONDUITS AND FITTINGS EXPOSED ON EXTERIOR WALLS SHALL BE PAINTED TO MATCH ADJACENT FINISH.
 - PROVIDE WATERPROOF PULL BOX ON EXTERIOR WALL. PULL BOX SHALL BE 12" X 18" X 4". MOUNT AT 5-FEET FROM TOP OF BOX TO FINISHED GRADE. VERIFY LOCATION WITH OWNER.

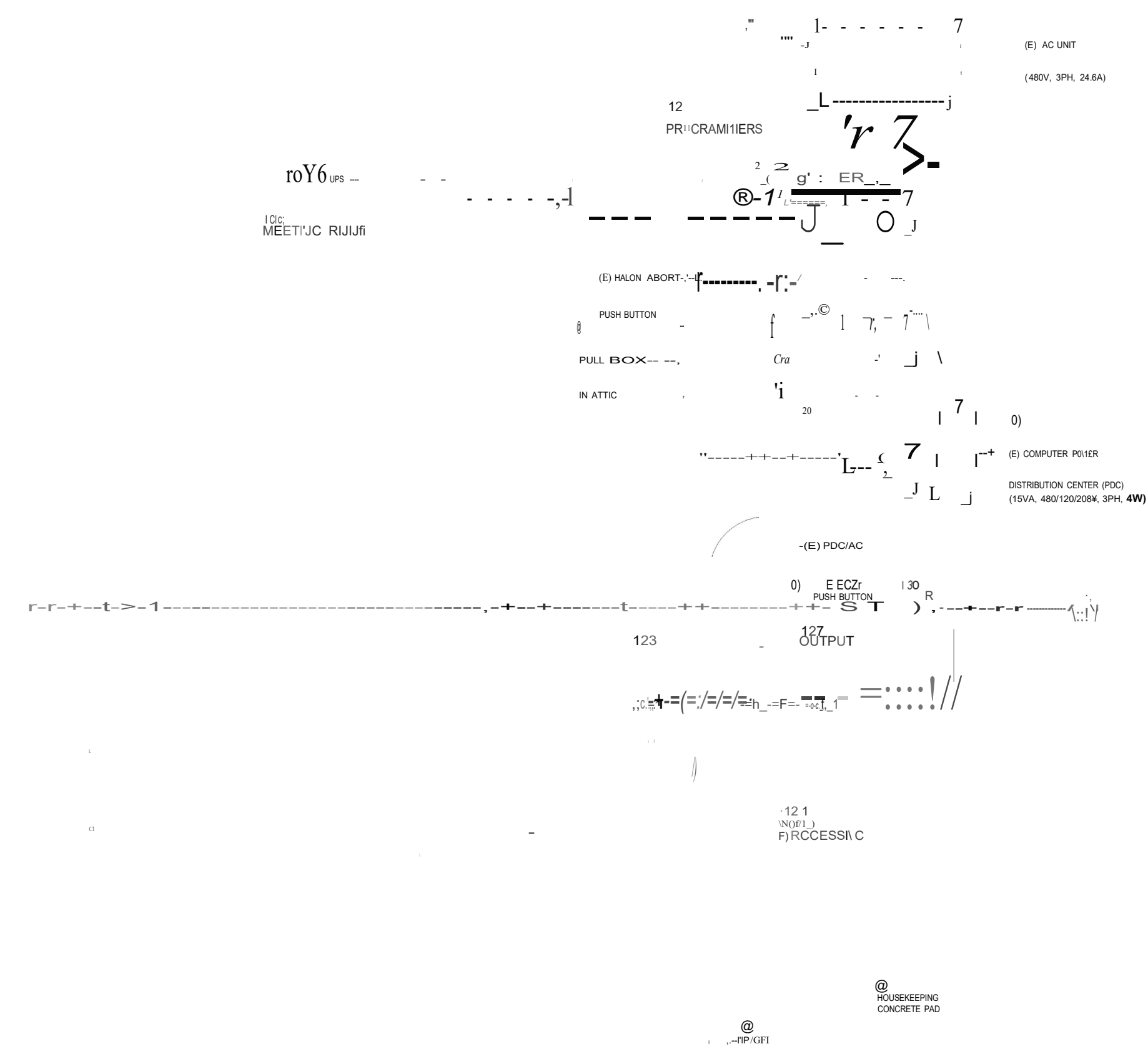

**FLOOR PLAN FOR
BACKUP GENERATOR
INFORMATION SYSTEMS COMPUTER ROOM
CITY OF MERCED**

PREPARED FOR:
CITY OF MERCED
678 WEST 18TH STREET
MERCED, CA 95340
(209) 385-4762

D:\Autocad LT 98\DWG\GWS\MCDR1\MCDR1E1.dwg F31 Apr 23

if/-, 1" = 1'-0" (LU...)

- PROVIDE WATERPROOF/GFI RECEPTACLE, RED FINISH FOR EMERGENCY, ON EXISTING WALL AS INDICATED, RUN 1/2" MTH 2#2 + 1#12 GROUND TO PULL BOX. CONNECT TO CIRCUIT 10.
- RUN 1" - 3/10 + 1#10 GROUND INTO GENERATOR HOUSING TO CONNECT WATER JACKET HEATER ON CIRCUIT #1, BATTERY CHARGER AND TIMECLOCK ON CIRCUIT 11. VERIFY CONNECTION LOCATION AND REQUIREMENT 11TH SUPPLIER PRIOR TO ROUGH-IN.
- PROVIDE NEW EMERGENCY GENERATOR PER SPECIFICATION. INSTALL PER DETAIL ON E2.
- REFER TO MOUNTING DETAIL ON E2. CONTRACTOR SHALL SAW CUT EXISTING PARTING AS REQUIRED FOR NEW HOUSEKEEPING PAO.
- SAW CUT AND PATCH EXISTING PARTING FOR NEW UNDERGROUND CONDUITS.

KEY PLAN
NOT TO SCALE

NORTH

NORTH

SCALE: 1/4" = 1'-0"

(E) SPRINKLER TIME BOX

80A/3P-

120 PARTITION STORAGE

PLANTER

(25) PULL BOX

GENERATOR CONTROL PANEL

(E) GAS METERS

(28) EMERGENCY DIESEL GENERATOR
(277/480V, 3PH, 4W, 40KW, 80% PF, 50KVA)

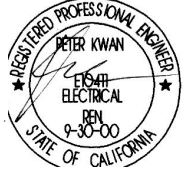

SHEET CONTENTS:

IBLIBCTRICAL IPII..AN

DESIGNED: PK

DRAWN BY: RCLS

CHECKED: *

DATE: 04/23/99

JOB NO.: 98-718

SHEET
E1
OF 2 SHEETS

(E) MAIN SWITCHBOARD
 (277/480V, 3PH, 4W, 1200A) CD

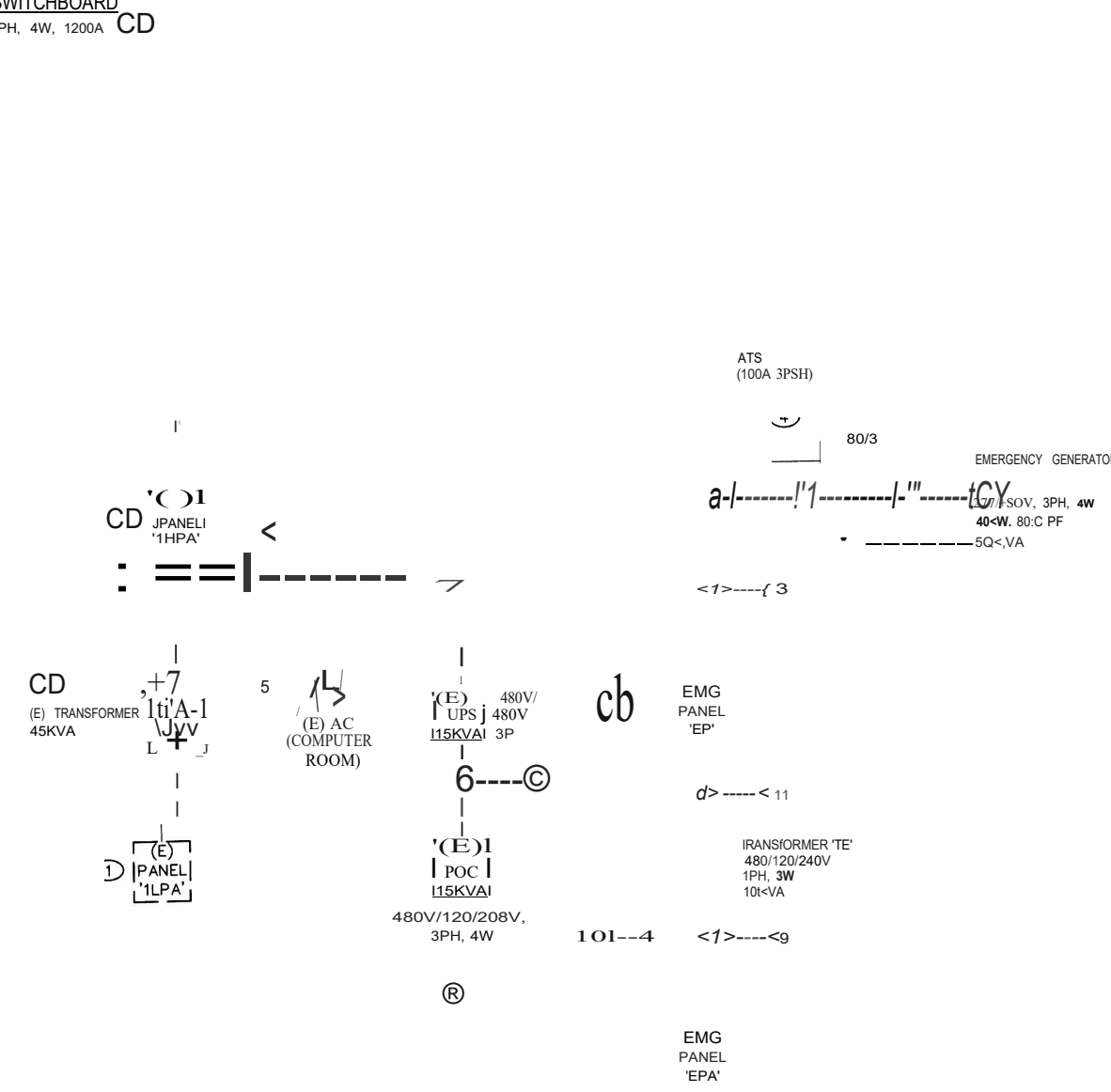

LINE DIAGRAM
 NTS

- LINE DIAGRAM NOTES:**
- (C) EXISTING TO REMAIN.
 - (D) PROVIDE NEW BREAKER IN EXISTING SPACE. MATCH EXISTING BREAKERS' AIC RATING.
 - (G) 1-1/2" - 4#4 + 1#8 GROUND.
 - (G) 1-1/4" - 4#4 + 1#8 GROUND FOR POWER AND 2#12 FOR GENERATOR START/STOP
- CONTROL FROM ATS. SEE ELECTRICAL PLAN ON E1 FOR ROUTING.
- EXISTING 1" WITH 3#10 FROM EXISTING PANEL "HPA" FOR EXISTING COMPUTER ROOM AC UNIT. INTERCEPT EXISTING CONDUIT AT PANEL WITH JUNCTION BOX. RUN NEW 1" WITH 3#10 + 1#10 GROUND FROM NEW EMG PANEL "EP" TO RECONNECT EXISTING WIRING.
- EXISTING FEEDER FOR EXISTING UPS. REMOVE EXISTING WIRING. ABANDON EXISTING CONDUIT IN PLACE.
- (f) 1" - #8 + 1#10 GROUND TO RECONNECT EXISTING UPS TO NEW EMG PANEL "EP".
 - (@) EXISTING PDC AND FEEDER TO REMAIN.
 - CD, C - 3#6 + 1#10 GROUND.
 - @ 1/2" WITH 1#8 GROUND TO EXISTING NEARBY METALLIC COID WATER PIPING AND BUILDING STEEL.
 - @ 1" - 2#10 + 1#10 GROUND.

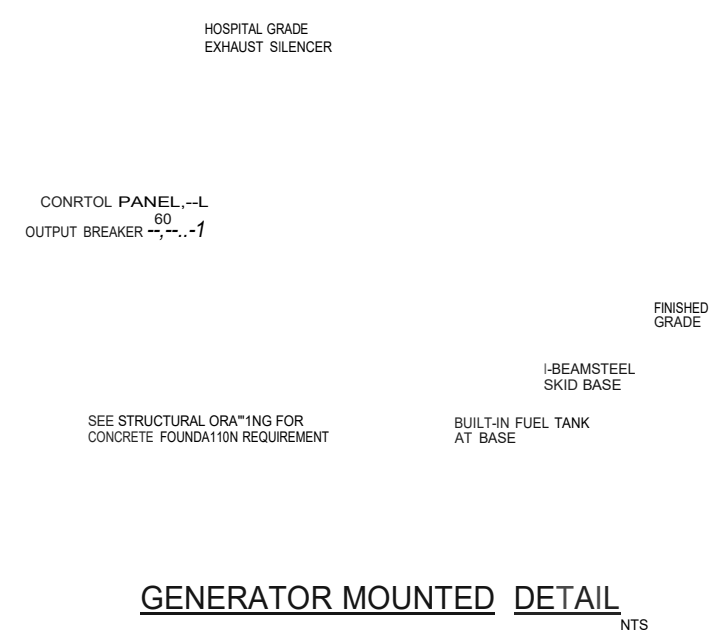

SURFACE PANEL MTG
 NTS

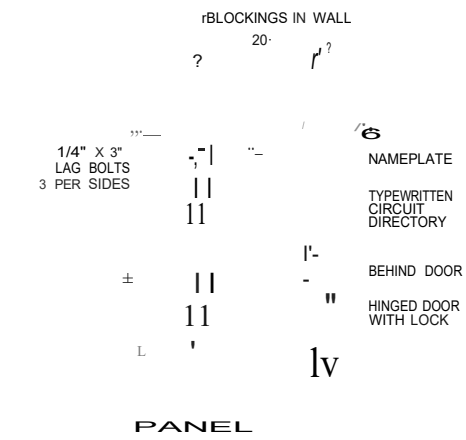

ELECTRICAL SYMBOLS (ALL DIMENSIONS TO CENTER OF BOX, U.O.N.)	
⌘	EXISTING SWITCH
⌘	EXISTING LIGHT
[FJ]	EXISTING FIRE ALARM PULL STATION
⌘ - -4	EXISTING CONDUIT AND WIRING
⌘ - -1	CONDUIT RUN IN WAU - ATTIC 1/2" - 2#12 + 1 1/2 GND, THHN/THWN-CU)
⌘ - -1	CONDUIT RUN IN FLOOR OR UG 2" - 2#12 + 1#12 GND, THHN/THWN-CU)
⌘	ELECTRICAL PANEL
⌘	DUPLEX RECEPTACLE, EMG (+15" U.O.N.)
⌘	DUPLEX RECEPTACLE IN WAU (+1" U.O.N.)
⌘	JUNCTION BOX
⌘	MOTOR OUTLET
CD	ELECTRICAL NOTE #1 (REFER TO ELECT NOTES ON SAME SHEET)
WP	WEATHERPROOF
GF1	GROUND FAULT CIRCUIT INTERRUPTER
U.O.N.	UNLESS OTHERWISE NOTED
(E)	EXISTING
PF	POWER FACTOR
EMG	EMERGENCY

TRANSFORMER MTG DETAIL
 NTS

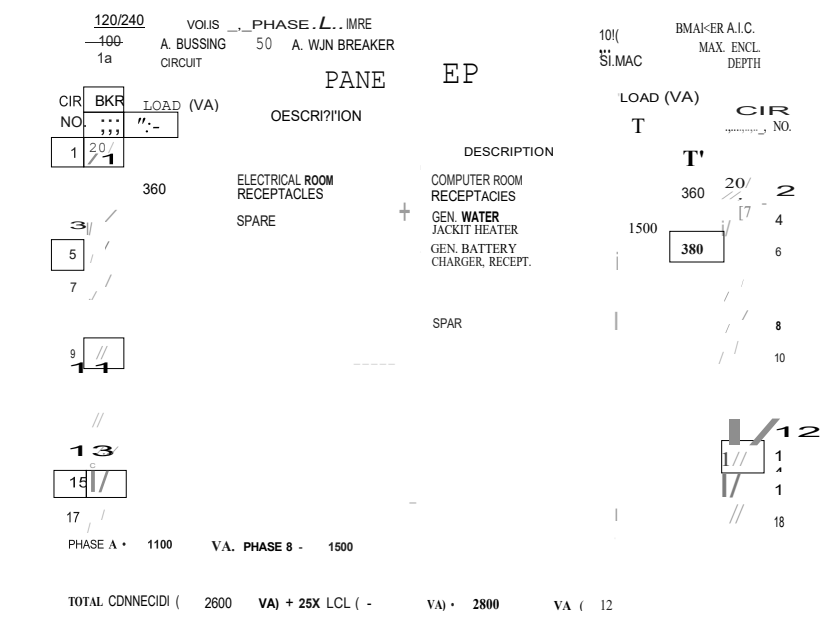
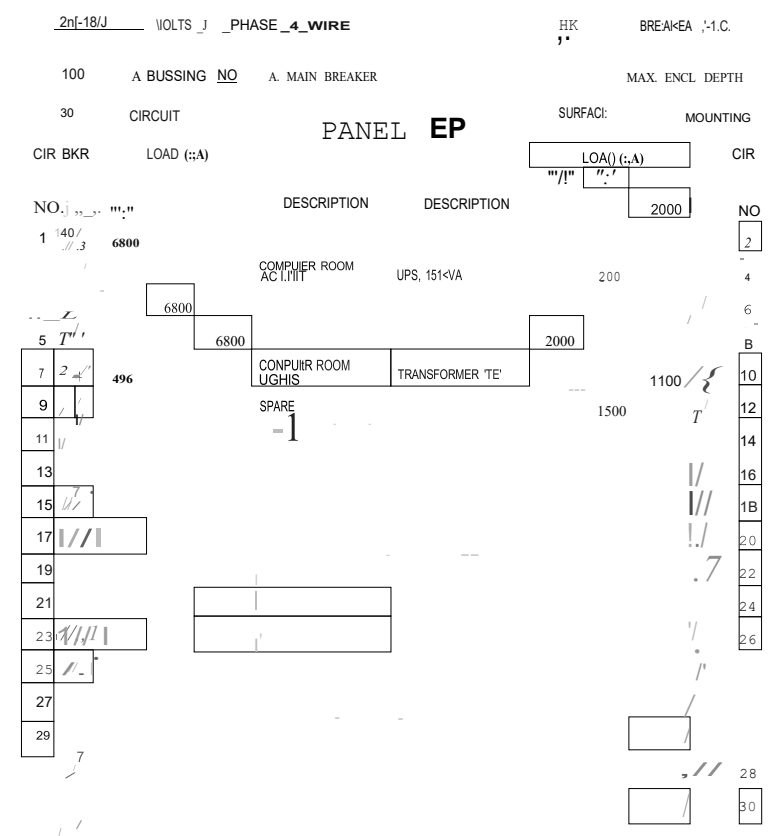
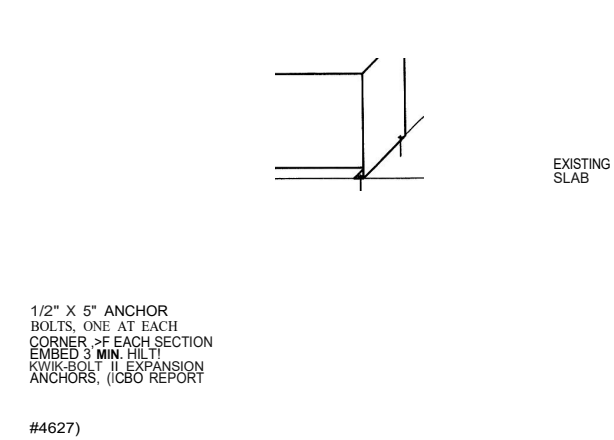

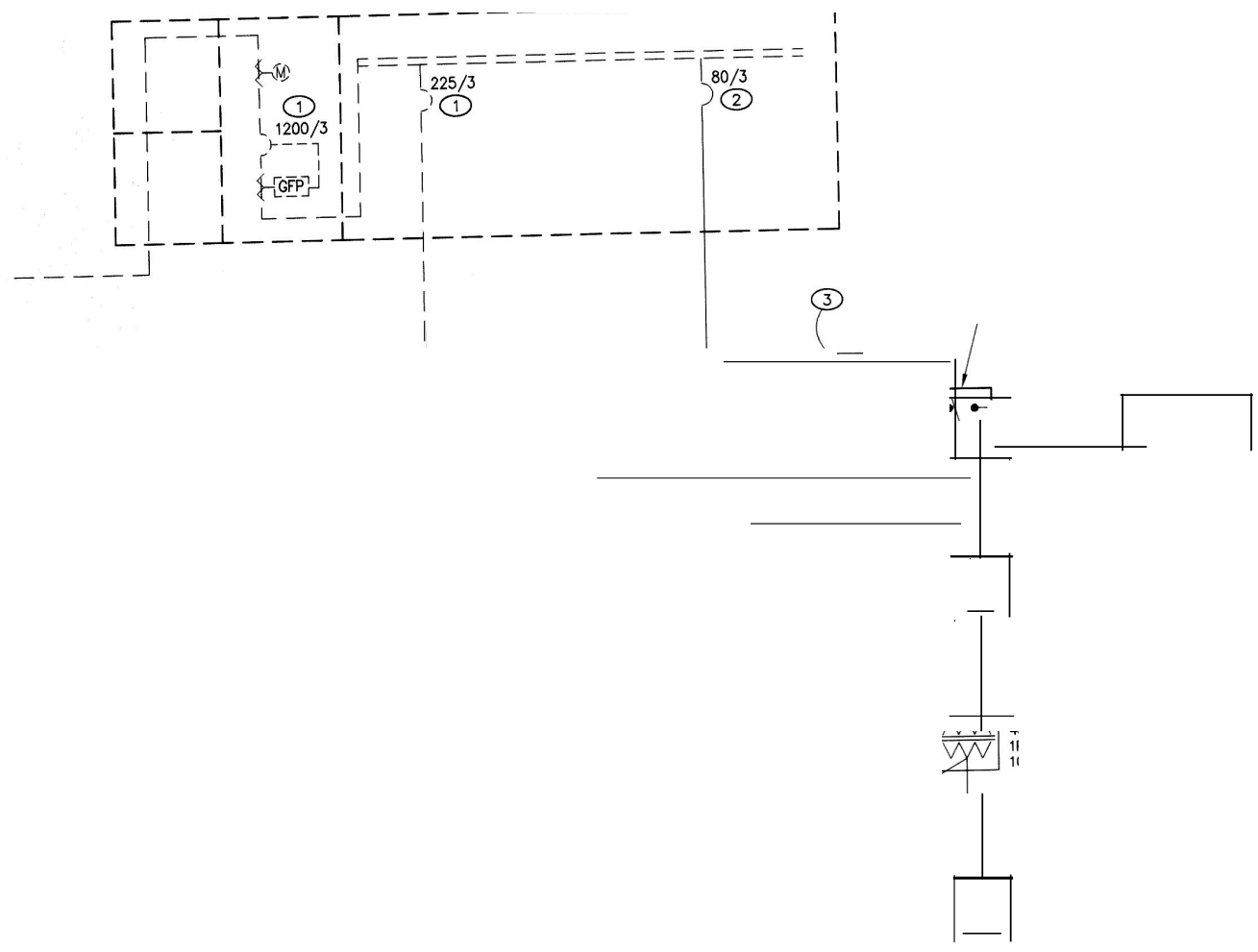

PHASE A = 10396 VA, PHASE B = 10100 VA, PHASE C = 8784 VA
 TOTAL CONNECTED (29496 VA) + 2511 LCL (12+ VA) = 29620 VA (37 AMP) MAX.

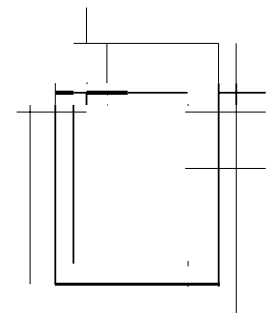
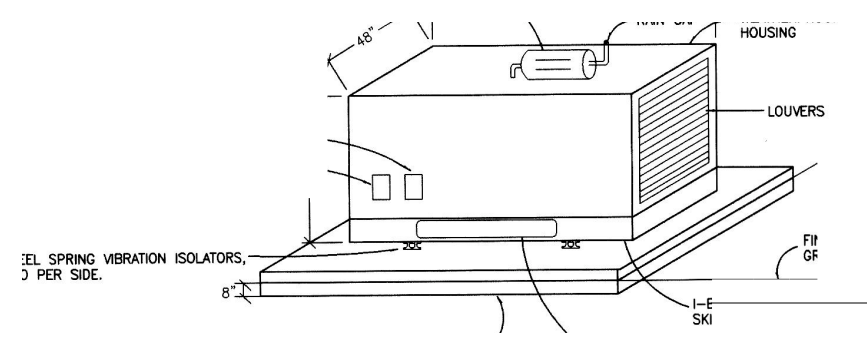

EQUIPMENT		DESCRIPTION		LOCATION	
1	1200/3	Panel	Control	Room 101	Panel
2	225/3	Panel	Control	Room 102	Panel
3	80/3	Panel	Control	Room 103	Panel
4	3	Panel	Control	Room 104	Panel

EQUIPMENT		DESCRIPTION		LOCATION	
1	1200/3	Panel	Control	Room 101	Panel
2	225/3	Panel	Control	Room 102	Panel
3	80/3	Panel	Control	Room 103	Panel
4	3	Panel	Control	Room 104	Panel

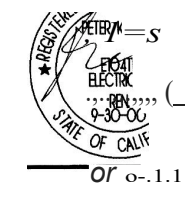

DESIGNED: PK
 DRAWN BY: RCLS
 CHECKED: *
 DATE: 04/23/99
 JOB NO.: 98- 718

SHEET
IE2
 OF 2 SHEETS

Exhibit A - Professional Service Contract

AGREEMENT FOR PROFESSIONAL SERVICES

THIS AGREEMENT is made and entered into this ____ day of _____, 20__, by and between the City of Merced, a California Charter Municipal Corporation, whose address of record is 678 West 18th Street, Merced, California 95340, (hereinafter referred to as “City”) and _____, a _____, whose address of record is _____, (hereinafter referred to as “Consultant”).

WHEREAS, City is undertaking a project to _____; and,

WHEREAS, Consultant represents that it possesses the professional skills to provide _____ services in connection with said project.

NOW, THEREFORE, the parties hereto, in consideration of the mutual covenants hereinafter recited, hereby agree as follows:

1. **SCOPE OF SERVICES.** The Consultant shall furnish the following services: Consultant shall provide the _____ services described in Exhibit “A” attached hereto.

No additional services shall be performed by Consultant unless approved in advance in writing by the City, stating the dollar value of the services, the method of payment, and any adjustment in contract time. All such services are to be coordinated with City and the results of the work shall be monitored by the _____ or designee. However, the means by which the work is accomplished shall be the sole responsibility of the Consultant.

2. **TIME OF PERFORMANCE.** All of the work outlined in the Scope of Services shall be completed in accordance with the Schedule outlined in Exhibit “B” attached hereto and incorporated herein by reference. By mutual agreement and written addendum to this Agreement, the City and the Consultant may change the requirements in said Schedule.

3. **TERM OF AGREEMENT.** The term of this Agreement shall commence upon the day first above written and end on _____, 20__.

4. **COMPENSATION.** Payment by the City to the Consultant for actual services rendered under this Agreement shall be made upon presentation of an

invoice detailing services performed under the Scope of Services, in accordance with the fee schedule set forth in Exhibit "C" attached hereto and incorporated herein by reference. The Consultant agrees to provide all services required under the Scope of Services in Exhibit "A" within the compensation amount set forth in Exhibit "C". For Consultant's services rendered under this Agreement, City shall pay Consultant the not to exceed sum of \$_____.

5. METHOD OF PAYMENT. Compensation to Consultant shall be paid by the City after submission by Consultant of an invoice delineating the services performed.

6. RECORDS. It is understood and agreed that all plans, studies, specifications, data magnetically or otherwise recorded on computer or computer diskettes, records, files, reports, etc., in possession of the Consultant relating to the matters covered by this Agreement shall be the property of the City, and Consultant hereby agrees to deliver the same to the City upon termination of the Agreement. It is understood and agreed that the documents and other materials including but not limited to those set forth hereinabove, prepared pursuant to this Agreement are prepared specifically for the City and are not necessarily suitable for any future or other use.

7. CONSULTANT'S BOOKS AND RECORDS. Consultant shall maintain any and all ledgers, books of account, invoices, vouchers, canceled checks, and other records or documents evidencing or relating to charges for services or expenditures and disbursements charged to the City for a minimum of three (3) years, or for any longer period required by law, from the date of final payment to the Consultant to this Agreement. Any records or documents required to be maintained shall be made available for inspection, audit and/or copying at any time during regular business hours, upon oral or written request of the City.

8. INDEPENDENT CONTRACTOR. It is expressly understood that Consultant is an independent contractor and that its employees shall not be employees of or have any contractual relationship with the City. Consultant shall be responsible for the payment of all taxes, workers' compensation insurance and unemployment insurance. Should Consultant desire any insurance protection, the Consultant is to acquire same at its expense.

In the event Consultant or any employee, agent, or subcontractor of Consultant providing services under this Agreement is determined by a court of competent jurisdiction or the California Public Employees Retirement System

(PERS) to be eligible for enrollment in PERS as an employee of the City, Consultant shall indemnify, protect, defend, and hold harmless the City for the payment of any employee and/or employer contributions for PERS benefits on behalf of Consultant or its employees, agents, or subcontractors, as well as for the payment of any penalties and interest on such contributions, which would otherwise be the responsibility of City.

CHOOSE WHICH INDEMNITY PROVISION APPLIES –

This indemnity provision applies to Vendor and Consultants providing general services to the City.

9. INDEMNITY. Consultant shall indemnify, protect, defend (with legal counsel selected by the City), save and hold City, its officers, employees, and agents, harmless from any and all claims or causes of action for death or injury to persons, or damage to property resulting from intentional or negligent acts, errors, or omissions of Consultant or Consultant’s officers, employees, volunteers, and agents during performance of this Agreement; Consultant shall indemnify, protect, defend (with counsel selected by the City) save and hold City, its officers, employees and agents harmless from any and claims or causes of action for any violation of any federal, state, or municipal law or ordinance, to the extent caused, in whole or in part, by the willful misconduct, negligent acts, or omissions of Consultant or its employees, subcontractors, or agents, or by the quality or character of Consultant’s work, or resulting from the negligence of the City, its officers, employees, volunteers and agents, except for loss caused by the sole negligence or willful misconduct of the City or its officers, employees, volunteers or agents. It is understood that the duty of Consultant to indemnify and hold harmless includes the duty to defend as set forth in Section 2778 of the California Civil Code. Acceptance by City of insurance certificates and endorsements required under this Agreement does not relieve Consultant from liability under this indemnification and hold harmless clause. This indemnification and hold harmless clause shall survive the termination of this Agreement and shall apply to any damages or claims for damages whether or not such insurance policies shall have been determined to apply. By execution of this Agreement, Consultant acknowledges and agrees to the provisions of this Section and that it is a material element of consideration.

This indemnity provision applies to Design Professionals that require errors and omissions coverage (Auditors, Attorneys, Architects, Engineers, Landscape Designers, Land Surveyors, etc.)

9. INDEMNITY.

A. Indemnity for Professional Liability. When the law establishes a professional standard of care for Consultant's Services, to the fullest extent permitted by law, Consultant shall indemnify, protect, defend, and hold harmless City and any and all of its officials, employees and agents from and against any and all losses, liabilities, damages, costs, and expenses, including legal counsel's fees and costs but only to the extent the Consultant (and its Subconsultants), are responsible for such damages, liabilities and costs on a comparative basis of fault between the Consultant (and its Subconsultants) and the City in the performance of professional services under this agreement.

B. Indemnity for Other Than Professional Liability. Other than in the performance of professional services and to the full extent permitted by law, Consultant shall indemnify, defend, and hold harmless City, and any and all of its employees, officials and agents from and against any liability (including liability for claims, suits, actions, arbitration proceedings, administrative proceedings, regulatory proceedings, losses, expenses or costs of any kind, whether actual, alleged or threatened, including legal counsel's fees and costs, court costs, defense costs, and expert witness fees), where the same arise out of, are a consequence of, or are in any way attributable to, in whole or in part, the performance of this Agreement by Consultant or by any individual or City for which Consultant is legally liable, including, but not limited to officers, agents, employees, or subcontractors of Consultant.

10. INSURANCE. During the term of this Agreement, Consultant shall maintain in full force and effect at its own cost and expense, the following insurance coverage:

a. Workers' Compensation Insurance. Full workers' compensation insurance shall be provided with a limit of at least One Hundred Thousand Dollars (\$100,000) for any one person and as required by law, including Employer's Liability limits of \$1,000,000.00 per accident. The policy shall be endorsed to waive the insurer's subrogation rights against the City.

- b. General Liability.
- (i) Consultant shall obtain and keep in full force and effect general liability coverage at least as broad as ISO commercial general liability coverage occurrence Form CG 0001.
 - (ii) Consultant shall maintain limits of no less than One Million Dollars (\$1,000,000) per occurrence for bodily injury, personal injury and property damage.
 - (iii) The City, its officers, employees, volunteers and agents are to be named as additional insureds under the policy, as respects liability arising out of work or operations performed by or on behalf of the Consultant.
 - (iv) The policy shall stipulate that this insurance will operate as primary insurance for work performed by Consultant and its sub-contractors, and that any other insurance or self insurance maintained by City or other named insureds shall be excess and non-contributory.
 - (v) Consultant shall maintain its commercial general liability coverage for three (3) years after completion of the work and shall add an additional insured endorsement form acceptable to the City naming the City of Merced, its officers, employees, agents and volunteers for each year thereafter for at least three (3) years after completion of the work. Copies of the annual renewal and additional insured endorsement form shall be sent to the City within thirty (30) days of the annual renewal.
- c. Automobile Insurance.
- (i) Consultant shall obtain and keep in full force and effect an automobile policy of at least One Million Dollars (\$1,000,000) per accident for bodily injury and property damage.
 - (ii) The City, its officers, employees, volunteers and agents are to be named as additional insureds under the policy, as respects automobiles owned, leased, hired or borrowed by the Consultant.

- (iii) The policy shall stipulate that this insurance will operate as primary insurance for work performed by Consultant and its sub-contractors, and that any other insurance or self insurance maintained by City or other named insureds shall be excess and non-contributory.

d. Professional Liability Insurance. Consultant shall carry professional liability insurance appropriate to Consultant's profession in the minimum amount of One Million Dollars (\$1,000,000). Architects and engineers' coverage is to be endorsed to include contractual liability.

e. Qualifications of Insurer. The insurance shall be provided by an acceptable insurance provider, as determined by City, which satisfies all of the following minimum requirements:

- (i) An insurance carrier admitted to do business in California and maintaining an agent for service of process within this State; and,
- (ii) An insurance carrier with a current A.M. Best Rating of A:VII or better (except for workers' compensation provided through the California State Compensation Fund).

f. Certificate of Insurance. Consultant shall complete and file with the City prior to engaging in any operation or activity set forth in this Agreement, certificates of insurance evidencing coverage as set forth above and which shall provide that no cancellation or expiration by the insurance company will be made during the term of this Agreement, without thirty (30) days written notice to City prior to the effective date of such cancellation—including cancellation for nonpayment of premium. In addition to any other remedies City may have, City reserves the right to withhold payment if Consultant's insurance policies are not current.

11. PREVAILING WAGES.

A. Labor Code Compliance. If the work performed under this Agreement falls within Labor Code Section 1720(a)(1) definition of a "public works" the Vendor agrees to comply with all of the applicable provisions of the Labor Code including, those provisions requiring the payment of not less than the general prevailing rate of wages. The Vendor further agrees to the penalties and

forfeitures provided in said Code in the event a violation of any of the provisions occurs in the execution of this Agreement.

B. These wage rate determinations are made a specific part of this Agreement by reference pursuant to Labor Code Section 1773.2. General Prevailing Wage Rate Determinations may be obtained from the Department of Industrial Relations Internet site at <http://www.dir.ca.gov/>.

C. After award of the Agreement, and prior to commencing work, all applicable General Prevailing Wage Rate Determinations, if applicable, are to be obtained by the Vendor from the Department of Industrial Relations. These wage rate determinations are to be posted by the Vendor at the job site in accordance with Section 1773.2 of the California Labor Code.

D. Vendor agrees to include prevailing wage requirements, if applicable, in all subcontracts when the work to be performed by the subcontractor under this Agreement is a “public works” as defined in Labor Code Section 1720(a)(1) and Labor Code Section 1771.

12. ASSIGNABILITY OF AGREEMENT. It is understood and agreed that this Agreement contemplates personal performance by the Consultant and is based upon a determination of its unique personal competence and experience and upon its specialized personal knowledge. Assignments of any or all rights, duties or obligations of the Consultant under this Agreement will be permitted only with the express written consent of the City.

13. TERMINATION FOR CONVENIENCE OF CITY. The City may terminate this Agreement any time by mailing a notice in writing to Consultant that the Agreement is terminated. Said Agreement shall then be deemed terminated, and no further work shall be performed by Consultant. If the Agreement is so terminated, the Consultant shall be paid for that percentage of the phase of work actually completed, based on a pro rata portion of the compensation for said phase satisfactorily completed at the time the notice of termination is received.

14. CONFORMANCE TO APPLICABLE LAWS. Consultant shall comply with its standard of care regarding all applicable Federal, State, and municipal laws, rules and ordinances. No discrimination shall be made by Consultant in the employment of persons to work under this contract because of race, color, national origin, ancestry, disability, sex or religion of such person.

Consultant hereby promises and agrees to comply with all of the provisions of the Federal Immigration and Nationality Act (8 U.S.C.A. 1101 *et seq.*), as amended; and in connection therewith, shall not employ unauthorized aliens as defined therein. Should Consultant so employ such unauthorized aliens for the performance of work and/or services covered by this Agreement, and should any agency or instrumentality of the federal or state government, including the courts, impose sanctions against the City for such use of unauthorized aliens, Consultant hereby agrees to, and shall, reimburse City for the cost of all such sanctions imposed, together with any and all costs, including attorneys' fees, incurred by the City in connection therewith.

15. **WAIVER.** In the event that either City or Consultant shall at any time or times waive any breach of this Agreement by the other, such waiver shall not constitute a waiver of any other or succeeding breach of this Agreement, whether of the same or any other covenant, condition or obligation. Waiver shall not be deemed effective until and unless signed by the waiving party.

16. **INCONSISTENT OR CONFLICTING TERMS IN AGREEMENT AND EXHIBITS.** In the event of any contradiction or inconsistency between any attached document(s) or exhibit(s) incorporated by reference herein and the provisions of the Agreement itself, the terms of the Agreement shall control.

Any exhibit that is attached and incorporated by reference shall be limited to the purposes for which it is attached, as specified in this Agreement. Any contractual terms or conditions contained in such exhibit imposing additional obligations on the City are not binding upon the City unless specifically agreed to in writing, and initialed by the authorized City representative, as to each additional contractual term or condition.

17. **AMBIGUITIES.** This Agreement has been negotiated at arms' length between persons knowledgeable in the matters dealt with herein. Accordingly, any rule of law, including, but not limited to, Section 1654 of the Civil Code of California, or any other statutes, legal decisions, or common-law principles of similar effect, that would require interpretation of any ambiguities in this Agreement against the party that drafted this Agreement is of no application and is hereby expressly waived.

18. **VENUE.** This Agreement and all matters relating to it shall be governed by the laws of the State of California and any action brought relating to this agreement shall be held exclusively in a state court in the County of Merced.

19. AMENDMENT. This Agreement shall not be amended, modified, or otherwise changed unless in writing and signed by both parties hereto.

20. INTEGRATION. This Agreement constitutes the entire understanding and agreement of the parties and supersedes all previous and/or contemporaneous understanding or agreement between the parties with respect to all or any part of the subject matter hereof.

21. AUTHORITY TO EXECUTE. The person or persons executing this Agreement on behalf of the parties hereto warrants and represents that he/she/they has/have the authority to execute this Agreement on behalf of their entity and has/have the authority to bind their party to the performance of its obligations hereunder.

22. COUNTERPARTS. This Agreement may be executed in one or more counterparts with each counterpart being deemed an original. No counterpart shall be deemed to be an original or presumed delivered unless and until the counterparts executed by the other parties hereto are in the physical possession of the party or parties seeking enforcement thereof.

IN WITNESS WHEREOF, the parties have caused this Agreement to be executed on the date first above written.

CITY OF MERCED
A California Charter Municipal
Corporation

BY: _____
City Manager

ATTEST:
STEPHANIE R. DIETZ, CITY CLERK

BY: _____
Assistant/Deputy City Clerk

APPROVED AS TO FORM:

BY: _____
City Attorney Date

ACCOUNT DATA:

BY: _____
Verified by Finance Officer

CONSULTANT

BY: _____
(Signature)

(Typed Name)

Its: _____
(Title)

BY: _____
(Signature)

(Typed Name)

Its: _____
(Title)

Taxpayer I.D. No. _____

ADDRESS: _____

TELEPHONE: _____

FAX: _____

E-MAIL: _____