

MEMORANDUM

DATE November 27, 2012

TO David B. Gonzalves, Director of Development Services
Kim Espinosa, Planning Manager

FROM Ben Noble, Associate Principal

RE **Zoning Code Issues and Options**

The City of Merced is undergoing a Comprehensive Update to its Zoning Ordinance, Title 20 of the Municipal Code. The City's existing Ordinance, which was written in 1960's and amended piece-meal over the subsequent decades, falls short of addressing specific contemporary land use and development issues of the City.

The Update process has a number of key goals:

1. Produce a modernized Zoning Ordinance that is in plain English, user-friendly, and has an easily readable format which is integrated with diagrams and tables for simplicity.
2. Help implement the new Merced Vision 2030 General Plan adopted in January 2012. The Zoning Ordinance is the primary way policies from the General Plan related to the physical dimensions of the city, land use pattern, activities, and land uses can be implemented. The updated Zoning Ordinance will set parameters of design, location, and permit conditions.
3. Produce a Zoning Ordinance that improves the permit issuance process for applicants, resulting in faster, more predictable outcomes.

This memorandum provides background information for the Comprehensive Zoning Ordinance Update public workshop to be held on November 28, 2012, and will also inform the preparation of the Draft Zoning Ordinance. The memo identifies a number of key issues for the update, and possible ways to address these issues. The memo is broken into two parts; Part A presents non-controversial, straight-forward changes to the existing Zoning Ordinance, and Part B presents more complex issues that deserve public attention and need community input.

Part A. Non-Controversial Changes

Below is a summary of anticipated changes to the existing Zoning Ordinance that are primarily non-controversial, straight-forward, and technical in nature. Opportunities for public review

and input for these changes will be provided through the hearing process and workshops for the updated Zoning Ordinance. We do not anticipate the need to discuss these items at the November 28th workshop.

- ◆ **Revision for Legal Compliance.** The City is obligated to revise the Zoning Ordinance in response to California laws related to zoning issues, including water efficient landscaping (AB 1881), location and standards for certain types of housing and homeless shelters (SB 2), requirements for farmworker housing (SB 1802), density bonuses for senior housing (SB 1818), and Cal Green requirements for bicycle parking (§ 5.106.4). Direction from City Council and Planning Commission, and comments from the public were previously received on how to specifically revise the Zoning Ordinance in response to state law.
- ◆ **Addition of Graphics and Tables.** Diagrams, illustrations, and tables will be added to the Ordinance. These additions will more efficiently communicate land use regulations for zoning districts, development standards for zoning districts, and unique provisions that benefit from graphic illustration.
- ◆ **Elimination of Supplementary Chapters.** Three “Catch-all” chapters, Non-conformities (20.60), Exceptions (20.62), and Special Provisions (20.54) contain land use and development regulations applicable to a variety of residential and commercial projects, but are located outside of the relevant sections. To simplify the use of the Ordinance and reduce the room for omissions, these three chapters will be relocated and directly incorporated in the relevant sections of the Ordinance.
- ◆ **Revision of Overall Organization.** The overall organization of the Zoning Ordinance will be changed, with information presented in a more intuitive manner. Similar provisions will be grouped together with related standards clearly cross-referenced. A user-friendly index to the zoning code will be added, and the layout of each page will be redesigned to speed up comprehension with less text per page, logical headings and integrated with diagrams.
- ◆ **Modernization of Language.** Much of the existing code consists of text created for those in the legal profession. Language will be substantially revised to convey the same meaning, but re-written in plain English, removing jargon to the greatest extent possible.
- ◆ **Addition of Modern Land Uses.** Approval for land uses which do not present conflicts, are non-controversial, and compatible with typical community land uses will be made

simpler through revising the permit process. This will include setting land use standards and conditions based on prior experiences of the community.

- ◆ **Internal Consistency.** We will ensure standards are the same across the entire Zoning Ordinance, so that the document has no contradictory information.
- ◆ **Elimination of Redundancies.** We will remove unnecessary repetitions of standards and regulations.
- ◆ **Implementation of General Plan.** The updated Zoning Ordinance will implement a variety of goals and polices in the recently adopted Merced General Plan. This will include the revision of standards for Downtown and South Merced, and the creation of new zoning districts to implement the General Plan land use map.
- ◆ **New Business Park Zone.** The updated Zoning Ordinance will contain a new Business Park Zone to implement the Business Park Land Use designation in the General Plan. This zone will allow for modern business park development, ensure high quality design in a campus-like setting, and provide for flexibility in land uses over time.

Part B. Items for Public Discussion

Complex issues worthy of public time and attention that need community input are discussed in this section of the memorandum. At the November 28, 2012 workshop, participants will be asked to provide feedback on these issues, with a particular focus on Downtown Merced.

For each topic below, the issue is first defined, followed by possible ways the updated Zoning Ordinance could address the issue. Input on these issues and options received at the November 28th workshop will help inform how the issues are addressed in the updated Zoning Ordinance.

1. Downtown Merced

The new General Plan envisions Downtown Merced as a vibrant arts, entertainment, and dining destination, with outdoor dining patios, downtown residences, and an active public realm during both the day and the evenings. The concept for downtown involves improving downtown, while retaining its unique qualities.

Options:

Ways in which the updated Zoning Ordinance can implement this vision for Downtown Merced include:

- i. **Design Standards:** Establish new building and site design standards which ensure high quality design for new development. These standards would address the fundamental “building blocks” for good urban design in a pedestrian-oriented downtown environment. These building blocks would address building placement on the lot, building orientation relative to the primary street, height and mass, setbacks, ground floor frontage design, parking design and placement, and other critical items. Design standards may also address less critical issues such as lighting, signage, landscaping, and building materials as appropriate. An example of zoning standards mandating high quality downtown development in San Bruno, California is attached to this memorandum as Attachment A.
- ii. **Approval Process:** Create streamlined, accelerated approvals for projects consistent with new design standards. Projects consistent with design standards for downtown development could be approved by-right with no discretionary review process. If the project complies with the standards, it is automatically approved at the staff level with no public hearing. Alternatively, the project could be approved through a process by which staff approves the project only if certain findings can be made (i.e., a staff-level discretionary process) with no Planning Commission hearing or approval needed. In either case, the public can be made aware of a pending action on a project and can review the proposed project application, submit a comment, request a public hearing, or appeal the staff level decision if desired.
- iii. **Land Use Regulations:** Revise land use regulations for downtown to discourage or prohibit problematic land uses. Currently there are a number of land uses in Downtown Merced that some community members feel may not contribute to the economic vitality of the area. Some community members have identified places of religious assembly (i.e., churches) and social service agencies as an example of such uses. The updated Zoning Code could revise existing land use regulations limiting these uses or encouraging their location in more appropriate areas. This could be done by prohibiting certain land uses in the core of Downtown, or establishing a maximum concentration requirement for these uses. The updated Zoning Code could also establish new findings required for the approval of certain uses in Downtown

Merced. For example, to allow an additional place of religious assembly or social service agency in Downtown Merced, the Planning Commission would have to find that the proposed use would contribute to an active and inviting environment and contribute to the of Downtown's general vitality.

- iv. **Incentives:** Create incentives for developers to include community benefits as part of new projects. Community benefits are project features that help to promote the vision and goals of the community, but which are not typically required by zoning regulations for a development project. Examples of community benefits may include affordable housing, sustainable building design, transportation demand management measures, social and cultural facilities, streetscape improvements, and public gathering places such as courtyards and plazas. The updated Zoning Code could encourage new projects to incorporate community benefits through an incentive-based system. For example, the City could grant additional allowable density or height to projects that incorporate high quality publicly-accessible gathering places or vertical mixed use with active ground floor uses such as restaurants with outdoor dining. Under this system, the bonus allowed would be calibrated to the general cost of providing the community benefit. An example of successful incentive zoning ordinance from the Town of Beekman, New York is provided in Attachment B.

2. Urban Village Zoning District

In contrast with subdivisions made up exclusively of houses, and also in contrast with shopping centers that exclusively provide space for retail stores, the General Plan calls for development to follow the Urban Village concept in the new growth areas of Merced. These new Urban Villages will combine a variety of uses in a relatively small area, making it convenient for walking, biking, or transit use.

Serving as the focal point of new development in Merced, the Urban Villages will provide higher density residential development adjacent to retail, commercial services, or job-generating uses. These bike-, pedestrian- and transit-friendly residential areas will be centered on a community gathering space, such as school, senior center, or retail center. These new growth areas will be laid out according to the Urban Village concept Land Use Diagram on page 3-55 of the General Plan, consisting of an Inner Village, Core Commercial, and Outer Village areas.

According to the Merced Vision 2030 General Plan, the Urban Villages should have the following characteristics:

- ◆ A mixture of residential densities, ownership patterns, costs, and dwelling types.
- ◆ Convenient walking and biking on trails, footpaths, and local and collector streets that provide by direct access from adjacent neighborhoods to destinations at the core.
- ◆ Building intensities and densities promote active centers, support transit, and encourage pedestrian-oriented development that fronts onto the street.
- ◆ Floor Area Ratio (FAR) is the ratio of a building's square footage in comparison to its landscaping/courtyard area. FAR is used to reduce density and encourage greenery, plazas, parking and courtyards. The Core Commercial areas in Merced should have a FAR of at least 1: 0.25.

Options:

Ways in which the updated Zoning Ordinance can implement the Urban Villages concept include:

- i. **New Mixed-Use Zones:** Create new mixed-use zones that allow for a mixing of land uses, a diversity of housing types, and a range of development intensities. Zoning districts intended for new growth areas in Merced do not permit the mixture of residential and commercial land uses. To build a mixed-use project outside of Downtown Merced, a developer must go through a Planned Development process, which can be lengthy and expensive with an uncertain outcome. The updated Zoning Code could include new mixed-use zoning districts intended for new growth areas, and could reflect the an Inner Village, Core Commercial, and Outer Village concepts described in the General Plan. These mixed-use zoning districts would allow for both vertical and horizontal mixed use, and would contain standards to ensure compatibility of adjacent land uses. An example of a transect-based mixed-use zoning district similar to what is envisioned for Merced's Core Commercial Urban Village areas is provided in Attachment C.
- ii. **Revised Planned Development Ordinance:** Revise Chapter 20.42 (P-D District) to reflect the Urban Village concept. Merced's existing Planned Development Ordinance establishes a process to allow development consistent with the General Plan but which deviates from the land use and development regulations of base zoning districts. This chapter could be revised to have a stronger connection to the

Urban Village concept in the General Plan. For example, the existing purpose statement (20.42.010) could make specific reference to Urban Villages. The chapter also could contain new development standards, land use regulations, and operational standards for the Inner Village, Core Commercial, and Outer Village areas of new Urban Villages in addition to existing provisions regarding other types of Planned Developments.

- iii. **New Flexible Permit:** Create a new type of permit that would allow adjustment of development standards. Creation of urban villages often require new building types that do not conform to typical development standards such as setbacks, lot coverage, and building height. As an alternative to a re-zoning to a Planned Development District, the updated Zoning Ordinance could contain a new type of permit that would allow for deviation from the development standards required by the applicable zoning district. This permit would require the Planning Commission to make a series of findings to ensure a high quality project with minimal impacts to neighboring properties. Such a permit is different from Planned Development re-zoning in that it would not require legislative action by the City Council and could be approved through a simpler process. An example of such a permit used in the City of Newport Beach is provided in Attachment D.
- iv. **Standards for Neighborhood Design:** Establish new design standards for the creation of new Urban Villages. The updated Zoning Ordinance could contain standards for the creation of new residential neighborhoods and commercial/mixed-use districts consistent with the General Plan's Urban Village concept. These standards would apply primarily to the subdivision of land and initial development of master-planned communities. Standards would address topics such as neighborhood size, connectivity, block length, activity centers, diversity of housing types, and walkability. These standards could streamline the Planned Development process, or entirely eliminate the need for a Planned Development rezoning. An example of traditional neighborhood residential subdivision design standards for the City of Tracy is provided in Attachment E.

3. South Merced

South Merced is a portion of the city south of downtown, extending from south of State Route 140 and State Route 99 to city limits. South Merced received special planning attention which

culminated in the creation and adoption of the *South Merced Community Plan (2007)*. The South Merced plan shares elements of the City's Urban Village concept, policies and designs guidelines, especially those which aim to make walking and biking safe and convenient. South Merced and the Urban Village also have similar aims for how residential and non-residential uses will work with each other. South Merced is unique in that it will include a wider variety of land uses.

The Merced Vision 2030 General Plan polices for South Merced are the following:

- ◆ Create a compatible combination land uses, including residential, open space, businesses park, commercial offices, agriculture, and industrial uses, in agreement with the *South Merced Community Plan*
- ◆ Promote a diversity of building types, ownership, prices, designs, and site plans in residential areas
- ◆ Apply concepts and designs from the Urban Village to South Merced
- ◆ Re-designate blighted areas, for example the auto wrecking yards on Childs Avenue and SR 99
- ◆ Locate commercial retail and offices uses on SR 59 corridor
- ◆ Facilitate development of bike friendly, pedestrian safe, and/or transit-oriented projects
- ◆ Create standards to extend the off-street pedestrian and bicycle trail south of SR 99
- ◆ Locate non-residential uses in the Merced Municipal Airport Clear Zones
- ◆ Establish special landscaping standards to create scenic corridors in South Merced
- ◆ Plan for compatibility with the enhancement of the existing Childs Avenue/SR 99 interchange

Options:

Possible ways the Zoning Ordinance can implement the goals of the Merced Vision 2030 for South Merced include:

- i. **Zoning Map Changes:** Amend the Zoning Map to encourage desired land uses in South Merced. There are currently areas in South Merced with blighted conditions that detract from the quality of life and economic vitality of the areas. The Zoning Map could be revised to change the land use regulations that apply in these areas. Zoning map revisions could expand the range of land uses permitted in these areas, and/or restrict permitted land uses such that existing blighting uses become

nonconforming. The auto wrecking yards on Childs Avenue and SR 99 are examples of areas where a Zoning Map amendment could apply.

- ii. **New Performance Standards:** Establish new performance standards that apply to problem uses in South Merced. The updated Zoning Code could establish stronger performance standards that apply to problem uses such as auto wrecking yards. The City could then establish new permitting and code enforcement provisions to ensure that these comply with these provisions. The updated Zoning Ordinance could also include amortization provisions to require the elimination of problem uses over time that are made nonconforming through the updated Zoning Map.
- iii. **Annexations:** Encourage annexation of auto wrecking yards. The City currently has little control over auto wrecking yards that are located in the county outside the City boundary. If these properties were annexed into the City, there could be increased opportunities for improvements and redevelopment. The updated Zoning Code could encourage annexation of these properties through incentives that are attractive to property owners.
- iv. **Incentives:** Create incentives for desired land uses in South Merced. South Merced residents have identified a number of land uses desired in their community: a full service grocery store, specialty markets, gathering spaces, playgrounds, and community gardens. The updated Zoning Ordinance could encourage a grocery store, specialty market, or quasi-public plazas through an incentives-based system. For example, a proposed project for a grocery store or other needed land use could be eligible for relaxed development standards if the applicant can demonstrate that such a concession is necessary for the project to be financially feasible. Incentives of this sort could be combined with a general effort to remove regulatory barriers to infill development and investment in South Merced. To help facilitate development of resident-serving spaces,, the updated Zoning Ordinance could allow community gardens anywhere in South Merced, and play spaces for children could be allowed as an by-right use on nonprofit (such as church) property.

4. Regulations For Specific Land Uses

Merced's Zoning Ordinance needs to address specific land uses that have unique characteristics or that may have adverse impacts on neighboring properties. The existing Zoning Ordinance does not address many of these uses; the existing Zoning Ordinance also

contains detailed regulations for antiquated land uses that are no longer present in the community.

Based on a review of the existing Zoning Ordinance and discussion with Staff and community stakeholders, we have identified the following land uses as needing specific regulations in the updated zoning code:

- Animal hospitals
- Bail bonds
- Bed and breakfast
- Boarding houses
- Bus shelters/stops
- Check cashing
- Community gardens
- Flea markets
- Fraternities/sororities
- Gas stations
- Group homes (6+ residents)
- Home occupations
- Live Performance venues
- Medical clinics, doctor's offices
- Mobile vendors
- Nightclubs
- Quasi-public use
- Recycling centers
- Religious
- Residential care facilities (hospices)
- Retail - outdoor display of merchandise
- Sober living
- Solar panels
- Studio apartments
- Tattoo studios
- Thrift stores

At the November 28th workshop, participants will have the opportunity to comment on whether we have correctly identified the specific land uses that need special regulations in the updated Zoning Ordinance.

5. Permit Processing

Presently in Merced, the permit approval process can be time consuming and expensive with an uncertain outcome for applicants and the community. This discourages investment, limits desirable changes in land uses, and slows the development of desirable projects. The permit approval process also consumes time of City Staff and the Planning Commission, requiring an excessive number of staff reports or public hearings for common uses such as residential units downtown, patio dining, and auto repair shops. The updated Zoning Ordinance should reduce red tape and streamline the development review process where possible while still producing

high quality development and ensuring community involvement in decisions on important or controversial development projects.

Options:

Ways to further streamline the permit process in the new Zoning Ordinance include:

- i. **By-Right Projects:** Increase the number of land uses and types of development projects that are permitted by-right. Currently, Merced's Zoning Ordinance requires a public hearing and discretionary permit for some types of projects which are closely aligned with the City's development goals and would not likely result in significant problems if approved. Downtown housing is a prime example of such a use, requiring Planning Commission approval of a Conditional Use Permit. The updated Zoning Ordinance could establish standards for certain land use projects and allow compliant uses by-right, thereby eliminate the need to formulate individual Conditional Use Permits. This would encourage desired forms of development and investment in the community by establishing standards for certain uses, thereby eliminating the need for
- ii. **Site-Plan Review:** Expand the existing Site Plan Review process to apply to a broader range of projects. Chapter 20.68 of the existing Zoning Ordinance requires Site Plan Review by a committee of City staff prior to approval of a building permit or a conditional use permit. The purpose of the Site Plan Review is to verify that the proposed project complies with all application development regulations. The updated Zoning Ordinance could use the Site Plan Review process as an alternative to time consuming and expensive Planning Commission approvals. An expanded Site Plan approval process would be most effective when combined with clear development and performance standards that can be easily interpreted and enforced by City staff.
- iii. **Staff-Level Discretionary Permit:** Create new discretionary permits for approval by City staff. Discretionary permits in the existing Zoning Ordinance include Conditional Use Permits, Variances, and Site Plan and Architectural Review approvals. Discretionary permits allow the judgment of the decision-makers as a basis to approve or deny a proposed project. In Merced, all discretionary permits are approved by either the Planning Commission or the Design Review Commission. The updated Zoning Ordinance could establish new discretionary permits, such as a

Minor Use Permit, a Minor Variance, or minor modifications to Conditional Use Permits, which would be approved by the Director of Development Services. The Director of Development Services would have the ability to attach conditions to the approval of these permits, and could also refer particularly controversial applications up to the Planning Commission for a higher level review.

Attachments:

- A. Prescriptive Downtown Design Standards Example: San Bruno, CA
- B. Incentive Zoning Example: Town of Beekman, NY
- C. Mixed-Use Zoning District Example: Livermore, CA
- D. Flexible Permit Example: Newport Beach, CA
- E. Neighborhood Design Standards Example: Tracy, CA

Appendix A

Prescriptive Downtown Design Standards Example: San Bruno, CA

Article 12.92 – MIXED USE ZONES

Sections:

12.92.010 – Zone Purposes

12.92.020 – Land Use Regulations

12.92.030 – Development Standards

12.92.010 – Zone Purposes

- A. Central Business District (CBD).** The purpose of the CBD zone is to support a vibrant downtown core that is an exciting destination for residents, workers, and visitors. The CBD zone will preserve and enhance the main street urban fabric and character of San Mateo Avenue with targeted enhancement of existing commercial uses, additional residential units, and streetscape improvements that create an inviting pedestrian environment. The CBD zone implements the Central Business District land use designation in the General Plan.
- B. TOD-Station Office (TOD-SO).** The purpose of the TOD-SO zone is to accommodate high intensity residential, office, and retail development within the vicinity of the new Caltrain station. New development within the TOD-SO zone will be a focal point of new activity that is integrated with the Caltrain station, Downtown San Bruno, and surrounding areas. The TOD zone will be a dynamic, active environment with a mixture of employment, residential, and retail uses that support a pedestrian-friendly environment. The TOD-SO zone implements the Transit-Oriented Development land use designation in the General Plan.
- C. Medium Density Mixed Use (TOD-1).** The purpose of the TOD-1 zone is to allow for a mixture of pedestrian-oriented land uses along San Bruno’s transit corridors. New development within the TOD-1 zone will support pedestrian activity, transportation alternatives, and a unique sense of place within San Bruno. High density housing will increase residents access to transit and support adjacent resident-serving retail and services. Streetscape improvements, upgraded storefront, and human-scaled building design will create a welcoming identity and inviting environment for pedestrians. The TOD-SO zone implements the Transit-Oriented Development land use designation in the General Plan.
- D. High Density Mixed Use (TOD-2).** The purpose of the TOD-2 zone is to allow for high intensity residential and commercial land uses along San Bruno’s primary transit corridors. New development within the TOD-2 zone will support a vibrant mixed use corridor that supports increased transit use and supports nearby stores and services. Building in the TOD-2 zone will encourage increased pedestrian activity and a high

quality design environment. The TOD-2 zone implements the Transit-Oriented Development land use designation in the General Plan.

12.92.020 – Land Use Regulations

A. Permitted Uses. Table 12.92-1 (Permitted Land Uses in Mixed Use Zones) identifies land uses permitted in each mixed use zone.

TABLE 12.92-1 PERMITTED LAND USES IN MIXED USE ZONE

Land Uses	Key					
	P Permitted land use C Conditional Use Permit required M Minor Use Permit required – Land use not allowed					
	Districts					Additional Provisions
CBD	TOD-S	TOD -1	TOD-2	MX-R		
Residential Uses						
Duplex Homes	-	-	-	-	-	
Live/Work	P [1]	P	P	P	P	Chapter 12.144
Mobile Home Parks	-	-	-	-	-	
Multiple-Family Homes	P [1]	P	P	P	P	Chapter 12.144
Residential Care Facilities, Small	P [1]	P	P	P	P	
Residential Care Facilities, Large	P [1]	P	P	P	P	
Secondary Dwelling Units	-	-	-	-	-	Chapter 12.144
Single-Family Homes	-	-	-	-	-	
Public and Quasi-Public Uses						
Cemetery	-	-	-	-	-	
Colleges and Universities	-	C	C	C	-	
Community Facilities	M	M	M	M	M	
Day Care Center	M	M	M	M	M	
Emergency Shelters	-	P	P	P	-	
Home Day Care, Small	P [1]	P	P	P	P	
Home Day Care, Large	M [1]	M	M	M	M	
Hospitals	-	-	-	-	-	
Medical Offices	-	P	P	P	C	
Nursing and Convalescent Homes	-	P	P	P	P	
Offices, Government	-	P	P	P	C	
Parks and Recreational Facilities	C	C	C	C	C	
Places of Worship	M	M	M	M	M	Chapter 12.144
Public Safety Facilities	-	-	-	-	-	
Public Maintenance Facilities	-	-	-	-	-	

Land Uses	Key					
	P Permitted land use C Conditional Use Permit required M Minor Use Permit required — Land use not allowed					
	Districts					Additional Provisions
CBD	TOD-S	TOD -1	TOD-2	MX-R		
Schools	C	C	C	C	C	
Social Services and Charitable Institutions	-	C	C	C	C	
Trade and Vocational Schools	-	C	C	C	C	
Commercial Uses						
Adult Businesses	-	-	C	C	-	Chapter 12.144
Bars, Nightclubs and Lounges	C	C	C	C	C	
Business Services	P [1]	M	M	M	M	
Check Cashing Establishment	-	-	M	M	-	Chapter 12.144
Commercial Recreation and Entertainment	C	C	C	C	C	
Gas and Service Stations	-	C	C	C	C	
Gun and Ammunition Sales	-	-	C	C	-	Chapter 12.144
Health and Exercise Clubs	-	C	C	C	C	
Hotels and Motels	-	P	P	P	C	
Pawn Shops	-	-	M	M	-	Chapter 12.144
Personal/Business Services	P [1]	P	P	P	C	
Personal Storage	-	-	-	-	-	
Professional Office	-	P	P	P	C	
Research and Development Facilities	-	C	C	C	-	
Retail Sales and Services	P	P	P	P	C	
Restaurants	P	P	P	P	C	Chapter 12.144
Vehicle Sales and Rental	-	-	-	C	-	Chapter 12.144
Vehicle Repair and Maintenance	-	-	-	C	-	
Industrial Uses						
Construction, Maintenance, and Repair Services	-	-	-	-	-	
Heavy Equipment Sales and Rental	-	-	-	-	-	
Lumberyards	-	-	-	-	-	
Manufacturing and Processing, Light	-	-	-	-	-	
Manufacturing and Processing, General	-	-	-	-	-	
Manufacturing and Processing, Heavy	-	-	-	-	-	
Warehousing, Wholesaling, and Distribution	-	-	-	-	-	
Transportation, Communication, and Utilities Uses						

Land Uses	Key					
	P Permitted land use C Conditional Use Permit required M Minor Use Permit required — Land use not allowed					
	Districts					Additional Provisions
CBD	TOD-S	TOD -1	TOD-2	MX-R		
Parking Lots, Commercial	-	-	-	-	-	
Parking Structures, Commercial	C	C	C	C	C	
Recycling Collection Facilities	-	M	M	M	M	
Recycling Processing Facilities	-	-	-	-	-	
Renewable Energy Structures	See Chapter 12.144					
Telecommunications Facilities	See Chapter 12.148					
Transportation Terminals	-	C	-	-	-	
Utilities, Major	C	C	C	C	C	
Utilities, Minor	P	P	P	P	P	
Other Uses						
Urban Agriculture	P	P	P	P	P	Chapter 12.144
Drive-Through Facilities	-	-	-	-	-	

Notes:

[1] Permitted on upper floors only

12.92.030 – Development Standards

- A. Zone Standards. Figures 12.92-1 through 12.92-4 and Tables 12.92-2 through 12.92-5 identify building form and placement standards in the mixed use zones.

This page is intentionally blank

Figure 12.92-1 CBD Zone Standards

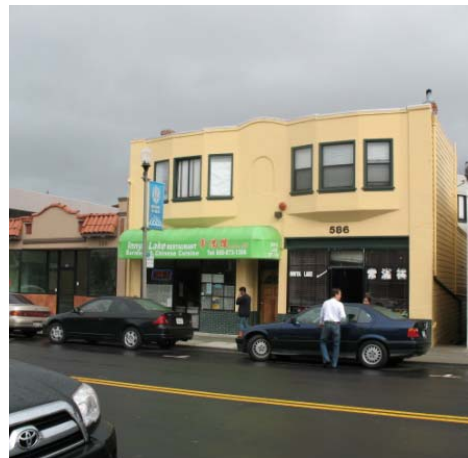
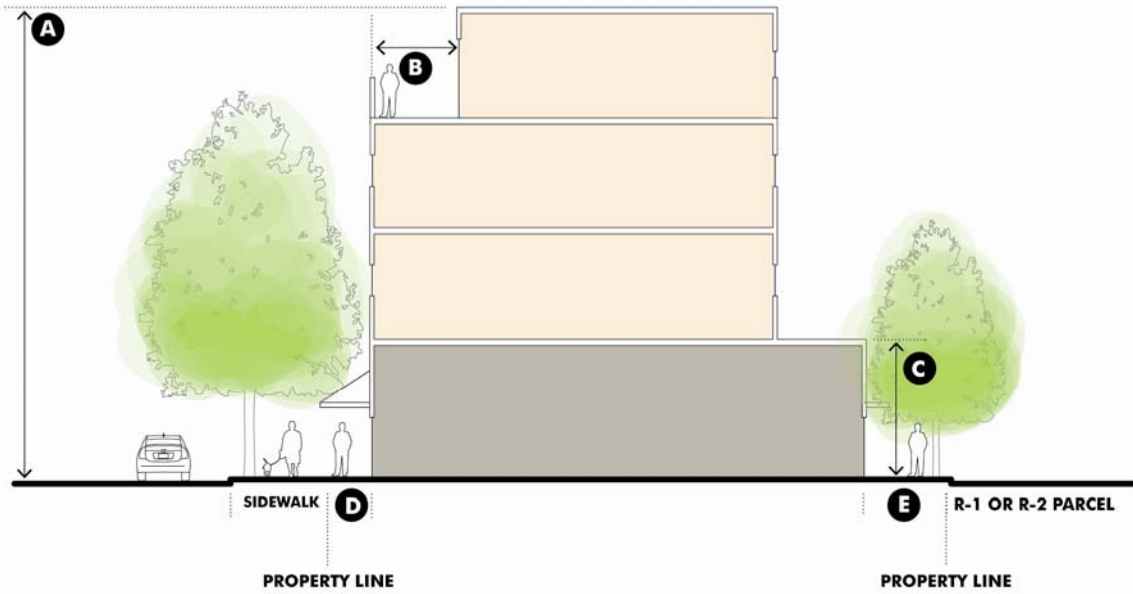

The CBD Zone is intended to preserve and enhance the main street urban fabric and character of San Mateo Avenue.

TABLE 12.92-2 DEVELOPMENT STANDARDS FOR THE CBD ZONE

Building Height	A	
Minimum		No minimum
Maximum		55 ft.
Ground floor Ceiling Height, Minimum	C	15 ft.
Upper Floor Stepbacks	B	10 ft. min. at 4 th floor and above when facing San Mateo Avenue or the R-1 or R-2 zones. See Section 12.92.030.B for additional stepback requirements in transition areas adjacent to existing single-family homes.
Floor Area Ratio		
Parcels less than 20,000 sq. ft.		2.0 maximum
Parcels 20,000 sq. ft.		No maximum
Setbacks		
Front and Street Side	D	Buildings shall be setback from the front property line so that the combined width of the sidewalk and setback is a minimum of 10 ft. If the width of the adjacent front sidewalk is 10 ft. or greater, no front setback is required. In no case shall a building be setback more than 5 ft. from the back of the adjacent sidewalk.
Interior Side		10 ft. minimum for parcels adjacent the R-2 zone; no required interior side rear setback for all other parcels
Rear	E	10 ft. minimum for parcels backing into the R-2 zone; no required rear setback for all other parcels

Figure 12.92-2 TOD-S Zone Standards



High intensity development within the TOD-S zone will support a dynamic and active environment within the vicinity of San Bruno's Caltrain station.

Table 12.92-3 Development Standards for the TOD-S Zone

Building Height		
Minimum	A	60 ft. west of San Mateo Avenue; no minimum east of San Mateo Avenue
Maximum	B	90 ft. west of San Mateo Avenue; 65 ft. east of San Mateo Avenue
Ground floor Ceiling Height, Minimum	D	12 ft. for office; 15 ft. for retail. Applies only to new construction.
Upper Floor Stepbacks	C	15 ft. min. at 6 th floor and above when facing San Bruno Avenue, at 5 th floor and above when facing San Mateo Avenue, and at 4 th floor and above when facing the R-1 or R-2 zone
Floor Area Ratio		
Parcels less than 20,000 sq. ft.		2.0 maximum
Parcels 20,000 sq. ft.		No minimum
Setbacks		
Front and Street Side	E	10 ft. minimum. Front setback must be pedestrian-oriented and contain semi-public amenities such as courtyards or outdoor seating areas.
Rear and Interior Side		None

Figure 12.92-3 TOD-1 Zone Standards

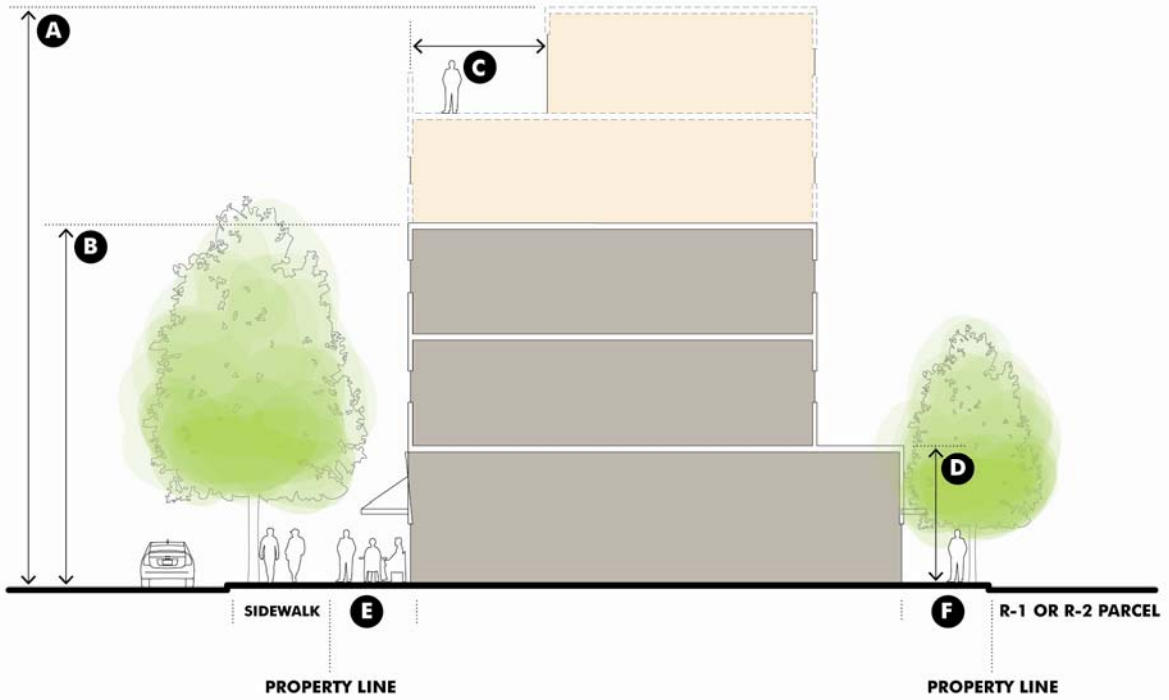

The TOD-1 zone allows for a mixture of land uses to support an active pedestrian environment along San Bruno Avenue.

TABLE 12.92-4 DEVELOPMENT STANDARDS FOR THE TOD-1 ZONE

Building Height		
Minimum	A	40 ft.
Maximum	B	65 ft.
Ground floor Ceiling Height, Minimum	D	15 ft.
Upper Floor Stepbacks	C	15 ft. min. at 5 th floor and above when facing San Bruno Avenue; 15 ft. min. at 4 th story and above when facing the R-1 or R-2 zone
Floor Area Ratio		
Parcels less than 20,000 sq. ft.		2.0 maximum
Parcels 20,000 sq. ft.		No minimum
Setbacks		
Front and Street Side	E	10 ft. minimum. Front setback must be pedestrian-oriented and contain semi-public amenities such as courtyards or outdoor seating areas.
Interior Side		None
Rear	F	10 ft. minimum for parcels backing into the R-1 or R-2 zone; no required rear setback for all other parcels

Figure 12.92-4 TOD-2 Zone Standards

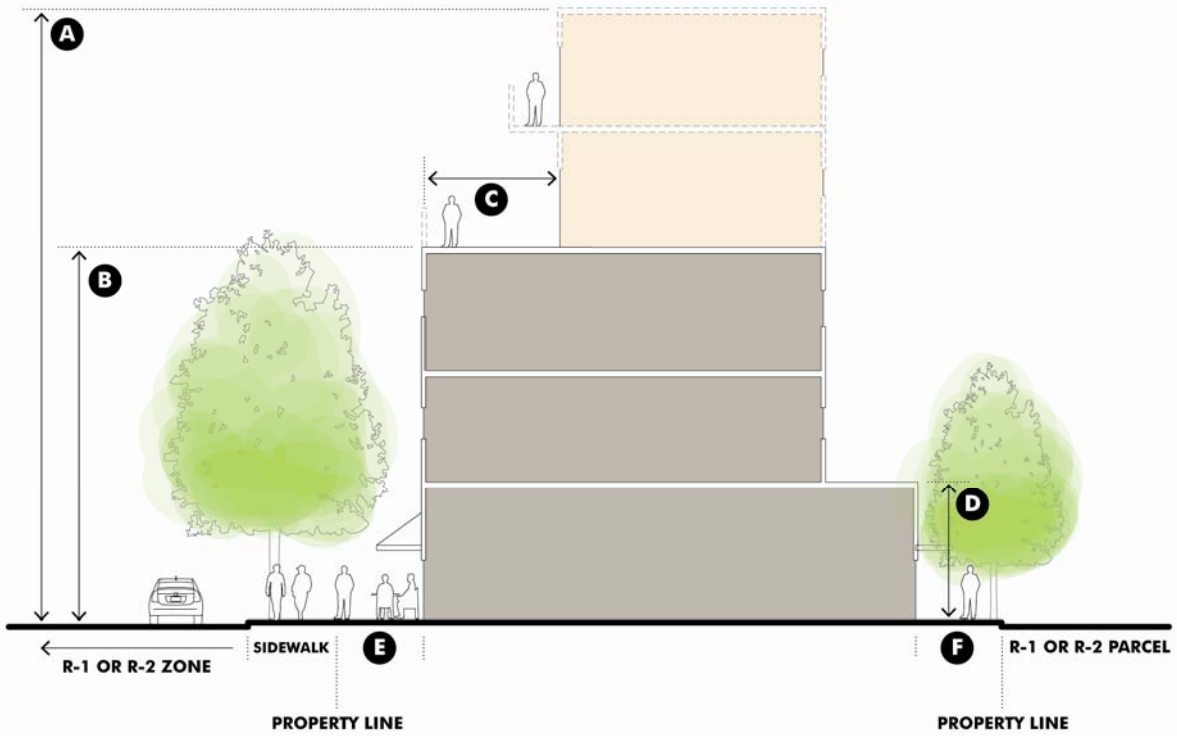

The TOD-2 zone allows high intensity residential uses to support increased transit use and economic vitality within San Bruno's transit corridors.

TABLE 12.92-5 DEVELOPMENT STANDARDS FOR THE TOD-2 ZONE

Building Height		
Minimum	A	40 ft.
Maximum	B	70 ft.
Ground floor Ceiling Height, Minimum	D	15 ft.
Upper Floor Stepbacks	C	15 ft. min. at 4 th story and above when facing the R-1 or R-2 zone
Floor Area Ratio		
Parcels less than 20,000 sq. ft.		2.0 maximum
Parcels 20,000 sq. ft.		No minimum
Setbacks		
Front and Street Side [1]	E	10 ft. minimum. Front setback must be pedestrian-oriented and contain semi-public amenities such as courtyards or outdoor seating areas.
Interior Side		None
Rear	F	10 ft. minimum for parcels backing into the R-1 or R-2 zone; no required rear setback for all other parcels

Notes:

[1] The Community Development Director may allow a reduced front or street side setback for parcels 100 feet or less in depth with the approval of a Minor Use Permit.

B. Required Stepbacks in Transition Areas.

1. **Transition Areas Defined.** Figure 12.92-5 (Transition Areas) identifies property lines adjacent to residential parcels from which additional upper floor building stepbacks are required.
2. **Stepbacks Required.** Upper floors of buildings within Transition areas shall be stepped back from rear and interior side property lines as follows:
 - a. 20 feet minimum at 4th floor and above when fronting rear property lines.

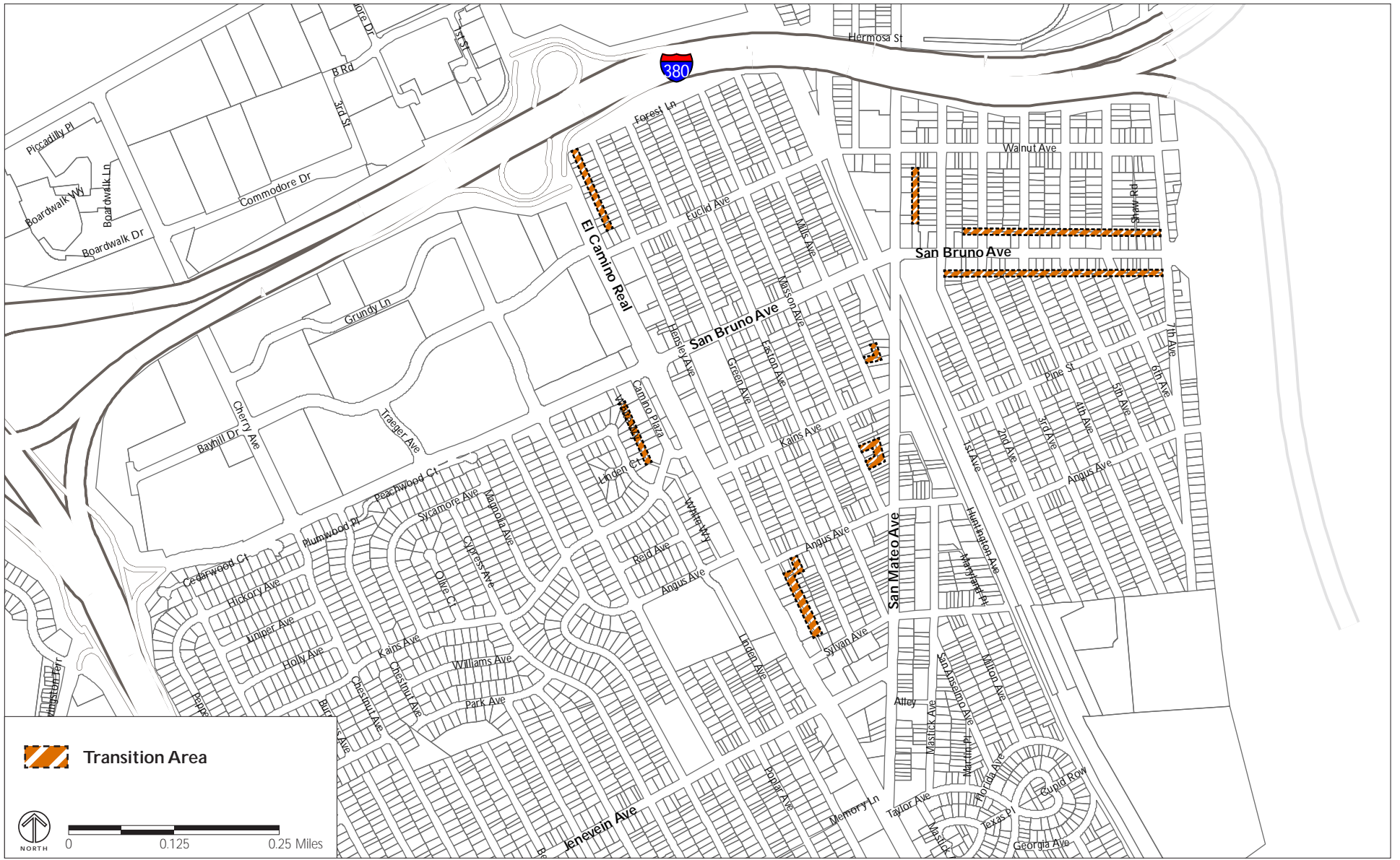

Source: City of San Bruno; The Planning Center | DC&E, 2012.

FIGURE X-X
TRANSITION AREAS

- b. 10 feet minimum at 4th floor and above when fronting interior side property lines.

C. **Development Standards that apply in all Mixed Use Zones.** The following standards apply to all primary buildings in all mixed use zones. These standards are illustrated in Figure 12.92-6 (Development Standards for all Mixed Use Zones).

1. **Building Orientation.** Buildings shall be oriented towards a public street with the primary entrance to the site or building directly accessible from an adjacent sidewalk.
2. **Blank Walls.** The maximum length of an unarticulated/blank building wall shall be 10 feet in the CBD zone and 25 feet in all other Transit Corridor Zones. Building articulation may be provided by:
 - a. Doors, windows, and other building openings;
 - b. Building projections or recesses, doorway and window trim, and other details that provide architectural articulation and design interest;
 - c. Varying wall planes, heights or contrasting materials and colors; and
 - d. Awnings, canopies or arcades to reinforce the pedestrian scale and provide shade and cover from the elements
3. **Storefront Width.** The maximum building/storefront width in the CBD shall be 25 feet and 100 feet in all other Transit Corridors Zones. Larger buildings shall be broken down into a pedestrian-scale rhythm with individual building bay widths of 25 to 50 feet.
4. **Ground Floor Building Transparency.**
 - a. The ground floor street-facing building walls of non-residential uses shall provide transparent windows or doors with views into the building for a minimum of 65 percent of the building frontage located between 2 ½ and 7 feet above the sidewalk.
 - b. Exceptions to this transparency requirement may be allowed with a Minor Use Permit if the Community Development Director finds that:
 - (1) The proposed use has unique operational characteristics which preclude building openings, such as for a cinema or theatre; and
 - (2) Street-facing building walls will exhibit architectural relief and detail, and will be enhanced with landscaping in such a way as to create visual interest at the pedestrian level.

Figure 12.92-6 Development Standards for all Mixed Use Zones

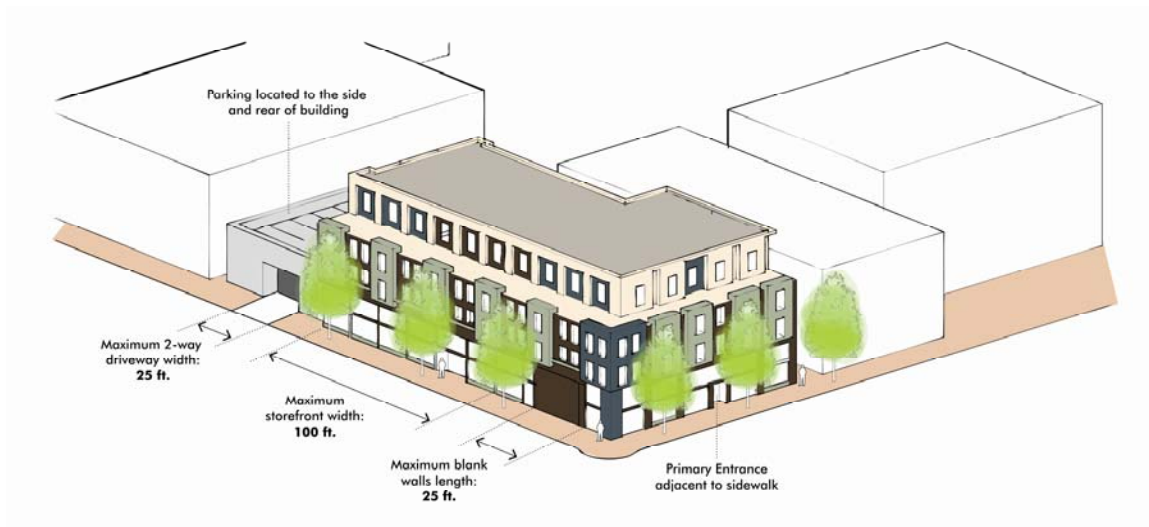

5. **Parking Location and Buffers.**

- a. Surface parking shall be located to the rear or side of buildings. Surface parking may not be located between a building and a street-facing property line.
- b. Parking completely or partially underground may match the setbacks of the main structure. The maximum height of a parking podium visible from a street is 5 feet from finished grade.
- c. Surface parking adjacent to a street-facing property line shall be screened along the public right-of-way with a decorative wall, hedge, trellis, and/or landscaping at least 3 feet in height.
- d. A landscaped buffer at least three feet in width and six feet in height shall be provided for any surface parking lot abutting a residential zone.
- e. Loading areas shall be located to the side and rear of buildings, and shall be sufficiently screened from the public right-of-way, as determined by the Community Development Director.

6. **Driveways and Curb Cuts.**

- a. New driveways shall comply with the dimension standards shown in Table 12.92-1 (Driveway Dimension Standards). The Community Development

Director may approve exceptions to these standards in the case of shared or joint use of driveways and parking lots.

- b. No new curb cuts for vehicle access shall be allowed along San Mateo Avenue.
- c. New curb cuts, where allowed, shall be located and designed to maximize safety and convenience for pedestrians, bicycles and mass transit vehicles, as determined by the Community Development Director.

TABLE 12.92-1 DRIVEWAY DIMENSION STANDARDS

Driveway Type	Driveway Width	
	Minimum	Maximum
1-way	8 ft.	12 ft.
2-way	20 ft.	25 ft.

Appendix B

Incentive Zoning Example: Town of Beekman, NY

Introduced at Regular Meeting of Town Board on October 15, 2001, by: Councilwoman Mauro

Dated: October 12, 2001

Placed on Desk of Town Board Members: October 12, 2001

Date of Public Hearing: November 19, 2001

Adopted: _____

Local Law No. __ of 2000
of the Town of Beekman

“INCENTIVE ZONING”

A LOCAL LAW TO AMEND the CODE OF THE TOWN OF BEEKMAN by adding a new section to Chapter 155 thereof, ZONING, to provide incentives to land development applicants for the provision of open space and public amenities.

BE IT ENACTED BY the Town Board of the Town of Beekman as follows:

Section 1.

The CODE OF THE TOWN OF BEEKMAN is hereby amended to add a new section 155-55 to Chapter 155, ZONING, to be entitled “**Incentive Zoning**”, to read as follows:

§ 155-55. Incentive zoning.

- A. Purpose and intent. The Town Board may grant zoning incentives to property developers to encourage the provision of certain community benefits or amenities, such as parks, open space, public active and passive recreational opportunities, and other physical, social, or cultural benefits or amenities that are in compliance with the Town Comprehensive Plan.
- B. Incentive zoning restricted to added benefits. Incentives shall be granted only when the community benefits or amenities offered would not otherwise be required or likely to result from the applicable planning process before the Planning Board. Such benefits shall be in addition to any items that are or would be required under other provisions of this chapter or State law, including any mitigation measures required pursuant to the State Environmental Quality Review Act.
- C. Allowable benefits for which incentives may be granted. The following may be offered either on or off the site of the subject application:
 - (1) (1) Permanent conservation of natural areas or agricultural lands;
 - (2) (2) Provision of passive or active open space and related improvements;

- (3) (3) Permanent protection of scenic views;
- (4) (4) Public Parks and recreational facilities;
- (5) (5) Public access to waterfronts;
- (6) (6) Public trails and trail linkages; or
- (7) (7) Cultural or historic facilities deeded to municipality or qualified not-for-profit agencies.

D. Incentives permitted.

- (1) The Town Board may grant the following incentives to the applicant on a specific site:

- (a) (a) Increases in residential unit density:

- [1] [1] The maximum number of residential dwelling units and/or lots permitted in an “incentive development” shall be the sum of the total number of conventional lots/dwelling units as determined pursuant to subdivisions G and C(3) of § 155-54 herein, plus an “incentive density,” which is the additional number of residential dwelling units/lots granted by the Town Board on the basis of the specific community benefits or amenities to be provided by the applicant.

- [2] [2] Where the plat falls within two or more contiguous districts, the Town Board may approve an incentive development representing the cumulative density as derived from the summing of all residential dwelling units and/or lots allowed in all such districts together with the incentive density, and may authorize actual construction to take place in all or any portion of one or more such districts.

- (b) (b) Increases in non-residential density:

- [1] [1] Decreases in required minimum lot area, setbacks or other bulk standards;

- [2] [2] Increases in impervious lot coverage, floor area ratios, building heights or other standards.

- (c) (c) Any other waivers of provisions of this chapter as deemed necessary and appropriate by the Town Board for the achievement of the community benefit or amenity.

E. Procedure and criteria for approval.

- (1) (1) Authorization of zoning incentives is subject to approval by the Town Board upon referral from the Planning Board prior to the grant of preliminary plat or preliminary site plan approval. Applicants may seek non-binding input from the Town Board as to whether the proposal is worthy of consideration prior to the application or at any stage of the application process prior to the formal referral of the application by the Planning Board pursuant to subdivision “6” below.
- (2) (2) For residential developments, applications for zoning incentives in exchange for community benefits shall be processed in accordance with the same procedures applicable to cluster development under § 155-54 herein (whether or not the incentive proposal is in conjunction with a cluster development), and shall include sketch and preliminary plat subdivision layouts for the proposed incentive development of the site.
- (3) (3) For non-residential developments, applications for zoning incentives in exchange for community benefits shall be processed in accordance with the site plan review procedures under § 155-59 herein, and shall include sketch plan and preliminary site plan layouts for the proposed incentive development of the site.
- (4) (4) To evaluate the adequacy of the proposed benefit(s) to be accepted in exchange for the requested incentive(s), the following information shall be provided by the applicant with its application for subdivision or site plan approval:
 - (a) (a) A description of the proposed amenity or amenities outlining the benefits that will accrue to the community;
 - (b) (b) The economic value of the proposed amenity or amenities to the Town as compared with the economic value of the proposed incentive or incentives to the applicant;
 - (c) (c) A preliminary demonstration that there is adequate sewer, water, transportation, waste disposal and fire protection facilities serving or proximate to the proposed development to handle the additional demands the incentive and amenity may place on such facilities beyond the demand that would otherwise occur with conventional subdivision development; and
 - (d) (d) An explanation as to the way in which the amenity will implement physical, social or cultural policies of the Comprehensive Plan and this Chapter.

- (5) All applicable requirements of the State Environmental Quality Review Act (“SEQRA”) shall be complied with as part of the review and hearing process before the Planning Board.
- (6) Prior to granting approval of the preliminary plat or preliminary site plan based on an incentive proposal but after at least one hearing thereon has been held, the Planning Board shall refer the proposal to the Town Board. The Planning Board’s report shall include the following:
 - (a) (a) The Planning Board’s recommendations regarding the proposal, including an evaluation of the adequacy with which the benefit(s) and incentive(s) fit the site and how they relate to adjacent uses and structures, and that such benefit(s) would not otherwise result as provided in § 155-55(B) above. The Planning Board’s evaluation shall be limited to planning, design and layout considerations, or such other issues as may be specifically referred to it by the Town Board;
 - (b) (b) A SEQRA determination as to whether the proposal will have a significant impact on the environment; and
 - (c) (c) An assessment that there is adequate sewer, water, transportation, waste disposal and fire protection facilities to serve the proposed incentive development, benefit(s) provided, and other impacted lands, and that such development will not substantially and deleteriously impact upon the development prerogatives of neighboring lands pursuant to the zoning and land-use regulations then in effect.
- (7) Upon receipt of the Planning Board’s referral, the Town Board shall hold a public hearing on the proposal. For Town Board public hearings on incentive zoning requests, notice of the hearing shall be published in the official newspaper of the town at least five (5) days prior to the date of the hearing.
- (8) For approval of an amenity/incentive proposal, the Town Board shall determine that the proposed amenity provides sufficient public benefit to provide the requested incentive. Thereafter, the Planning Board is authorized to act on the application for preliminary approval pursuant to the Subdivision Regulations and or § 155-59 of this Chapter.
- (9) Following preliminary plan approval and subject to meeting all conditions imposed on the preliminary plan, including all conditions and documentation required by the Town Board for the incentive, the applicant may submit a final plat or plan for review and approval of the incentive proposal in accordance with the Subdivision Regulations or § 155-59.

Section 3. Severability.

If any section of this local law or the application thereof to any person or circumstance shall be adjudged invalid by a court of competent jurisdiction, such order or judgment shall be confined in its operation to the controversy in which it was rendered and shall not affect or invalidate the remainder of any provision of any section of the application of any part thereof to any other person or circumstances, and to this end, the provisions of each section of this local law are hereby declared to be severable.

Section 4. Effective date.

This local law shall take effect immediately upon its filing with the Secretary of State.

Appendix C

Mixed-Use Zoning District Example: Livermore, CA

3.02.040 Neighborhood Mixed-Use (NMU) Zone

A. Purpose.

The intent of the Neighborhood Mixed-Use zone (NMU) is to reinforce the walkability and identity of neighborhoods by providing a pedestrian-oriented main street shopping environment that provides day-to-day amenities and services, and a variety of urban housing options within Livermore.

B. Applicability.

1. This zone is applicable to areas designated as NMU on the zoning map.
 - a. The existing site located at Pine Street and Rincon Avenue (APN 098035100605) and the site located at South Livermore Avenue and Pacific Avenue (APNs 098A041210605, 098A041210608, 098A041210603 and 098A041210606) shall be able to maintain and/or add on building square footage and be subject to the Neighborhood Commercial (CN) zoning requirements found in Appendix A, rather than the NMU zoning requirements. Once these sites develop using the NMU zone, the CN zone shall be null and void. Sites shall not be permitted to use the NMU zone until such time as the entire site develops. The CN and NMU zones shall not be used at the same time. The total floor area shall not exceed the maximum floor area ratio specified in the CN zone. Subject to the floor area ratio limitation in the CN zone, no more than 50% (subject to the Director's discretion to allow a larger limit), of the existing building's floor area shall require compliance with the NMU zone. Maintenance and remodeling of the existing buildings, consistent with CN standards, shall not be considered as demolition of such buildings.
2. This zone may also be applied to other parcels, through a zoning map amendment process, in locations in which it makes sense to provide a neighborhood main street environment to complete a walkable neighborhood. A General Plan amendment may be required.
3. This zone may be applied to up to 10 acres of a parcel, 80 acres or more designated as Urban Medium Residential, and Urban Medium High Residential on the General Plan land use map to create a complete walkable neighborhood rather than just housing. A General Plan amendment may be required.
4. This zone may also be applied to parcels designated as Neighborhood Commercial, Office Commercial, and Community Serving General Commercial on the General Plan land use map to create mixed-use center or allow for the transformation of auto-dependent areas in to more walkable mixed-use environments. A General Plan amendment may be required.

C. Building form standards.

1. This zone is unlike other zones in that development is to be regulated by using a required mix of the T4 Main Street, T4 Main Street-Open, T4 Neighborhood, and T4 Neighborhood-Open transect zones to create a diverse and vibrant neighborhood mixed-use environment. Table 3.2 shows the required range of the mix of Transect zones within NMU planning sites.

Transect Zone	Minimum % of Land	Maximum % of Land
T4 Neighborhood	25% min.	80% max.
T4 Neighborhood Open	0% min.	50% max.
T4 Main Street Open	10% min.	50% max.
T4 Main Street	10% min.	20% max.

D. **Block standards.** See Section 2.01.020 (Subdivision Design Standards for All Zones) for applicable block standards for Transect zones.

E. **Frontage standards.**

1. Allowed frontages are determined by zone.
2. Min. 30% of residential units within T4 Neighborhood must have porches.
3. Min. 25% of T4 Main Street lineal frontage must have galleries.
4. See Chapter 4.03 (Frontage Standards) for complete frontage design standards.

F. **Thoroughfares.**

1. Must be selected from those defined and regulated in Part 7 (Thoroughfare Types).

G. **Civic space standards.**

1. For standards specific to Civic Space Types see Part 8 (Civic Space Types).
2. Projects shall set aside five percent of the project area as civic space (calculated after street rights-of-ways are taken out), except as follows:
 - a. Sites less than four acres: No civic spaces required.
 - b. Sites less than eight acres and within 1,000 feet of a public park of at least one acre and with a playground: No civic spaces required.
3. Each residential lot shall be within 1,000 feet of an existing or proposed playground or tot lot.
4. Civic spaces shall be fronted by buildings or by thoroughfares with building frontage on all sides.

H. **General development standards.**

1. When adjacent to existing residential uses all structures more than two stories in height shall be placed a minimum of 50 feet from adjoining property lines.

I. **Regulating plan standards.**

1. A Regulating Plan with street and block framework and transect zone application must be created and approved as part of the review process (see figure 3.1 for Regulating Plan example). See handout for submittal requirements for NMU projects.
2. Transect zone allocation.
 - a. T4 Main Street-Open must be adjacent to T4 Main Street.
 - b. T4 Neighborhood-Open must be adjacent to T4 Main Street or T4 Main Street-Open.
 - c. T4 Main Street must be applied to define a two-sided retail street.
 - (1) Minimum length of each side of the Main Street is 150 feet.



Figure 3.1: Example of a Regulating Plan

Appendix D

Flexible Permit Example: Newport Beach, CA

20.52.060 Planned Development Permits.

A. Purpose. The purpose of this section is to provide a process for approving a planned development permit that is intended to:

1. Ensure efficient use of land and a better living environment. Provide a method whereby land may be designed and developed as a unified site by taking advantage of efficient site planning techniques thereby resulting in a more efficient use of land, a better living environment, excellence of design, and related enhanced amenities than is otherwise possible through strict application of the development standards identified in Part 2 of this title (Zoning Districts, Allowable Land Uses, and Zoning District Standards);
2. Ensure high standards of environmental quality. Ensure development that meets high standards of environmental quality, public health and safety, the efficient use of the City's resources, and the purpose, intent, goals, policies, actions, and land use designations of the General Plan, and any applicable specific plan; and
3. Provide for enhanced amenities. Incorporate a program of enhanced amenities (e.g., enhanced landscaping, additional and enhanced open space, improvements to an existing public facility (e.g., park or trail, etc.)) than typically required by this Zoning Code.

B. Applicability.

1. Allowed in All Zoning Districts. A planned development permit may be requested for any zoning district.
2. Minimum Site Area. A planned development permit may only be requested for a site(s) with a minimum of one acre.
3. Uses Only Allowed in Base Zoning District. A planned development permit may not authorize a use that is not allowed in the base zoning district.
4. Adjustment of Standards.
 - a. The permit may adjust, where necessary and justifiable, all applicable development standards identified in this Zoning Code, with the exception of an increase in the applicable density or intensity. Height adjustments shall be limited to those identified in Section 20.30.060 (Height Limits and Exceptions).
 - b. Residential projects with increased density or intensity standards may only be approved in compliance with Chapter 20.32 (Density Bonus).
5. Site Development Review Not Required. A site development review shall not be required with a planned development permit application.

C. Application Filing, Processing, and Fees. An application for a planned development permit shall be filed and processed in compliance with Chapter 20.50 (Permit Application

Filing and Processing). The application shall include all of the information and materials specified by the Director, together with the required fee in compliance with the City's fee schedule adopted by resolution. It is the responsibility of the applicant to provide evidence in support of the findings required by subsection (F) of this section (Findings and Decision).

D. Review Authority. The Commission may approve, conditionally approve, or deny the planned development permit application, based upon the findings contained in subsection (F) of this section (Findings and Decision).

E. Project Review, Notice, and Hearing.

1. Application Consistent with the Purpose of Section. Each planned development permit application shall be reviewed by the Director to ensure that the application is consistent with the purpose and intent of this section.

2. Public Notice and Hearing Provisions.

a. Notice of hearing shall be provided and the hearing shall be conducted in compliance with Chapter 20.62 (Public Hearings).

b. A public hearing shall be required for the Commission's action on a planned development permit application.

F. Findings and Decision. The Commission may approve or conditionally approve a planned development permit application only after first finding all of the following:

1. The proposed development would:

a. Include only uses allowed within the base zoning district;

b. Be substantially consistent with the purpose, intent, goals, policies, actions, and land use designations of the General Plan, and any applicable specific plan;

c. Be substantially consistent with the purpose and intent of the base zoning district;

d. Include sustainable improvement standards and protection of environmental resources; and

e. Be compatible with other development within the zoning district and general neighborhood of the proposed project.

2. The project would produce a development of higher quality and greater excellence of design than that might otherwise result from using the standard development regulations;

3. The subject site is adequate in terms of size, shape, topography, and circumstances to accommodate the proposed development;

4. The project, as conditioned, will not have a substantial adverse effect on surrounding properties or allowed uses;

5. The project includes improved quality of life provisions and enhanced amenities, including an additional and appropriate variety of structure placement and orientation opportunities, appropriate mix of structure sizes, high quality architectural design, common open space, landscaping, parking areas, private open space, public art, recreational amenities for adults and/or children, private or separated entrances, sustainable improvement standards (e.g., energy efficient building design, construction, and operation; convenient pedestrian and bicycle circulation; water and resource conservation), etc.; and

6. The design, location, operating characteristics, and size of the project would be compatible with the existing and future uses in the vicinity, in terms of aesthetic values, character, scale, and view protection.

G. Minor Changes by Director.

1. Minor changes in the planned development permit that do not involve an increase in the number of dwelling units or intensity of other use or a change of use may be approved by the Director in compliance with Section 20.54.070 (Changes to an approved project).

2. Proposed changes that are not deemed minor shall be subject to review and approval by the original review authority.

H. Post-Decision Procedures. The procedures and requirements in Chapter 20.54 (Permit Implementation, Time Limits, and Extensions), and those related to appeals and revocation in Part 6 of this title (Zoning Code Administration) shall apply following the decision on a planned development permit application. (Ord. 2010-21 § 1 (Exh. A)(part), 2010)

Appendix E

Neighborhood Design Standards Example: Tracy, CA

Residential Subdivision Design Guidelines for TN Zones
To be incorporated into the City of Tracy Design Goals and Standards

Goals:

1. Create new residential neighborhoods with a distinctive sense of place.
2. Ensure that neighborhoods are well connected to adjacent development.
3. Provide a street pattern with varying character and function within each neighborhood that includes convenient pedestrian access to focal points, such as parks.
4. Ensure a variety of housing types within neighborhoods based on historic precedence.
5. Design neighborhoods that create streetscapes appropriately scaled for pedestrian activity.

Applicability:

Development Review shall be required for any residential tentative map, initial construction of single-family or two-family dwelling, and as otherwise required in Tracy Municipal Code Section 10.08.3940. These TN zone design standards shall be enforced and incorporated into the project design during the project's Development Review process. After a project's residential units have been constructed, Development Review shall not be required except as prescribed by Tracy Municipal Code Section 10.08.3940.

Standards:

1. Focal Points.

- a. **Focal Point Defined.** Focal points are locations that serve as meeting places where people can gather. Examples of focal points include parks and other public open spaces, community centers, and neighborhood-serving commercial areas. The City may accept other features as focal points.
- b. **Distance to Dwelling Units.** All dwelling units shall be a maximum of one-quarter mile from a focal point.

2. Block Lengths.

- a. **Measurement of Block Length.** Block lengths shall be measured as the length of property abutting one side of a street between either the two nearest intersecting streets or the nearest such street and any other physical barrier to the continuity of development. As shown in Figure 1 (Measurement of Block Length), block lengths shall be measured from property lines that intersect as an angle of 45 degrees or more.
- b. **Standards.** Except as permitted by subsection c below, block lengths shall comply with the standards in Table 1.

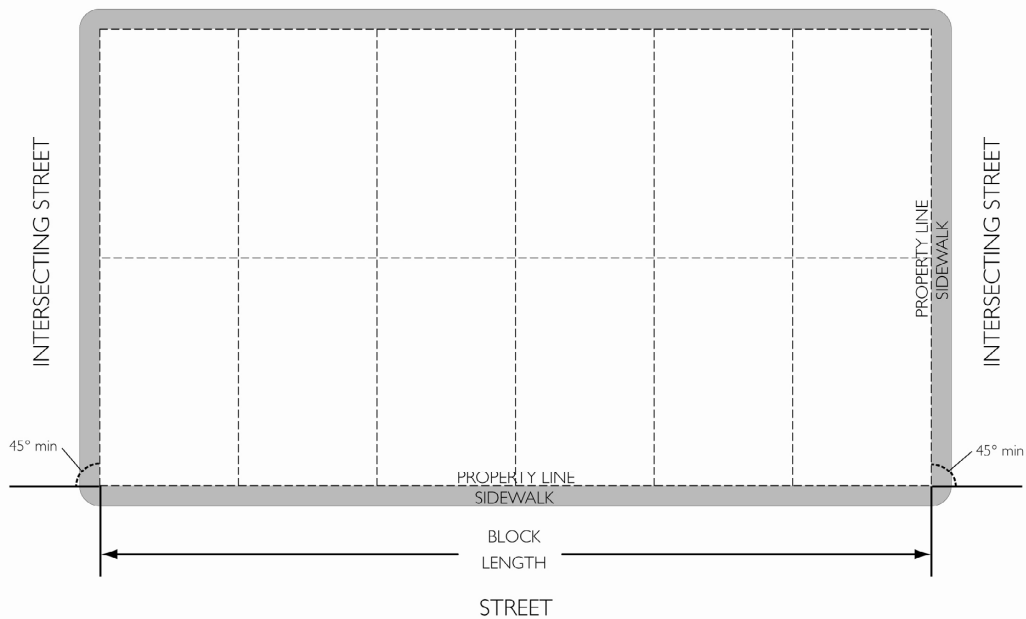

Figure 1 Measurement of Block Length

TABLE 1 PERMITTED BLOCK LENGTHS

		TN Zones		
		Neighborhood Edge (NE)	Neighborhood Mix (NM)	Neighborhood Core (NC)
Block Length	Minimum	300 ft.	300 ft.	200 ft.
	Maximum	750 ft.	500 ft.	500 ft.

c. **Exceptions.** The City may approve exceptions to the block length standards in Table 1 (Permitted Block Lengths) when necessary to achieve project compliance with connectivity and walkability standards in subsection 3 and 4 below, or if there are physical limitations, such as the size of the project area, that prevent attaining these standards.

3. Connectivity.

- a. **Adjacent Undeveloped Land.** For a residential development abutting undeveloped land, one roadway or pedestrian/bicycle path shall intersect the boundary at least every 400 feet. Exceptions to this requirement may be approved by the City Council if existing physical barriers render a connection infeasible.
- b. **Adjacent developed land.** For a subdivision boundary abutting developed land, streets intersecting the boundary shall align and connect with all adjacent streets and pathways.

- c. **Intersection Density.** Intersections shall be provided at a minimum density of 200 street intersections per square mile.
- d. **Cul-de-sacs.** Bicycle/pedestrian connections shall be provided at each cul-de-sac end, where feasible.

4. Walkability.

- a. **Traffic Calming.** Traffic calming measures, such as speed lumps, traffic circles, raised intersections and center islands, shall be incorporated into project designs as needed to support a pedestrian-oriented environment. Specific traffic calming measures included in a project shall be consistent with the City of Tracy Traffic Calming Program.
- b. **Pedestrian Routes.** Pedestrian routes from dwelling units to focal points within a subdivision shall not cross any arterial street or expressway as defined in the City of Tracy Standard Plans, unless those crossings have crosswalks and either traffic signals or stop signs.

5. Building Types.

a. Building Types Defined.

- i. A building type is a particular kind of structure with its own recognizable identity. Building types are defined primarily by their form (mass, scale and design).
- ii. These design standards distinguish between two categories of building types: primary buildings and secondary buildings. A primary building is the dominant and principle structure on a lot. A secondary building is accessory and subordinate to one or more primary buildings located on the same lot.

- b. **Diversity of Building Types.** Neighborhoods shall contain a diversity of building types, as specified in Table 2 (Required Building Type Diversity).

TABLE 2 REQUIRED BUILDING TYPE DIVERSITY

	TN Zones		
	Neighborhood Edge (NE)	Neighborhood Mix (NM)	Neighborhood Core (NC)
Maximum units of one building type	85%	65%	50%
Minimum number of building types (a)	3	4	4

(a) Detached single-family homes shall not exceed 50 percent of the total dwelling units in the NM zone and 30 percent of the total dwelling units in the NC zone.

- c. **Permitted Primary Building Types.** Primary building types permitted within each TN zone shall be only as shown in Table 3 (Permitted Primary Building Types).

TABLE 3 PERMITTED PRIMARY BUILDING TYPES

Primary Building Type	TN Zones		
	Neighborhood Edge (NE)	Neighborhood Mix (NM)	Neighborhood Core (NC)
Detached Home	P	P	-
Side Yard House	P	P	-
Cottage Home	P	P	-
Bungalow Court	-	P	P
Duplex	P	P	P
Mansion Apartment	P	P	P
Side Court Apartment	-	P	P
Courtyard Apartment	-	P	P
Townhouse	-	P	P
Stacked Dwelling	-	P	P

- d. **Unlisted Building Types.** To promote creativity and innovation in the design of new neighborhoods, the City may permit building types other than those listed in Table 3 (Permitted Primary Building Types). For the City to approve unlisted building types, the unlisted building types must meet the following requirements:
- i. The building type is consistent with the desired design character of the zone;
 - ii. The building type expands the diversity of housing choices and products within a neighborhood; and
 - iii. Inclusion of the building type will aid in compliance with building type diversity requirement in subsection b (Diversity of Building Types) above.
- e. **Standards that Apply to all Building Types.** The following standards apply to all building types unless otherwise indicated in subsection f (Building Types Standards) below.
- i. **Orientation.** Front entrances to buildings shall face onto or be clearly visible from a public street.
 - ii. **Corner Lots.** Buildings on corner lots shall feature well-articulated facades for each street frontage.
 - iii. **Pathways.** A pathway shall connect the adjacent public sidewalk to a building’s front entry.
 - iv. **Frontages.** Buildings shall feature frontage types consistent with requirements in Section 8 (Frontage Types) below.

- v. **Alley-Loaded Buildings.** For buildings served by an alley, vehicle access to the lot is allowed only through the alley. When an alley is present, vehicle parking areas, including garages, carports and surface parking spaces, shall be set back from the front lot line a minimum of 50 percent of the total lot depth. Utilities, above ground equipment, trash containers and other services shall be accessed only through the alley.
 - vi. **Front-Loaded Buildings.** For front-loaded buildings without an alley, vehicle parking area, including garages, carports or surface parking spaces, shall be set back a minimum of 5 feet from the front façade of the building. Attached garages shall comprise no more than 50 percent of front building façade.
 - vii. **Podium Parking.** Podium parking shall not front a street or public open space. Podium parking shall be lined by either dwelling units or commercial space.
- f. **Building Type Standards.** Standards that apply to individual building types are identified below.
- i. **Detached Home.**
 - a) **Description.** A detached home is a single dwelling unit designed to be occupied by one household. The rear yard serves as the primary private outdoor space for residents. Figure 2 (Detached Home Standards) illustrates key development standards for detached homes.

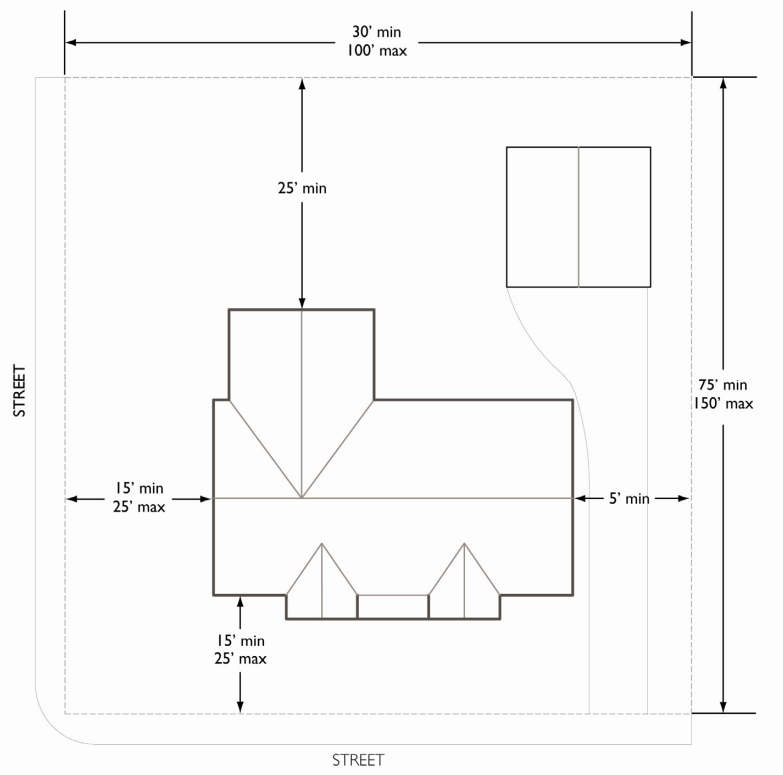

Figure 2 Detached Home Standards

- b) **Lot Dimensions.** Lots occupied by a detached home shall comply with the dimension standards in Table 4 (Lot Dimension Standards for Detached Homes).

TABLE 4 LOT DIMENSION STANDARDS FOR DETACHED HOMES

	Min.	Max.
Width	30 ft.	100 ft.
Depth	75 ft.	150 ft.

- c) **Setbacks and Height.** Detached homes shall comply with the setback and height standards in Table 5 (Setback and Height Standards for Detached Homes).

TABLE 5 SETBACK AND HEIGHT STANDARDS FOR DETACHED HOMES

	Min.	Max.
Setbacks		
Front	15 ft.	25 ft.
Interior Side	5 ft.	-
Street Side	15 ft.	25 ft.
Rear	25 ft. [1]	-
Height		30 ft.

[1] The minimum rear setback shall be five feet when abutting an alley.

ii. **Side Yard House.**

- a) **Description.** A side yard house is an alley-loaded single dwelling unit designed to be occupied by one household. Its lot includes a side yard that serves as the unit's primary private outdoor space for residents. Figure 3 (Side Yard House Standards) illustrates key development standards for side yard houses.
- b) **Lot Dimensions.** Lots occupied by a side yard house shall comply with the dimension standards in Table 6 (Lot Dimensions for Side Yard House).

TABLE 6 LOT DIMENSION STANDARDS FOR SIDE YARD HOUSES

	Min.	Max.
Width	40 ft.	100 ft.
Depth	50 ft.	150 ft.

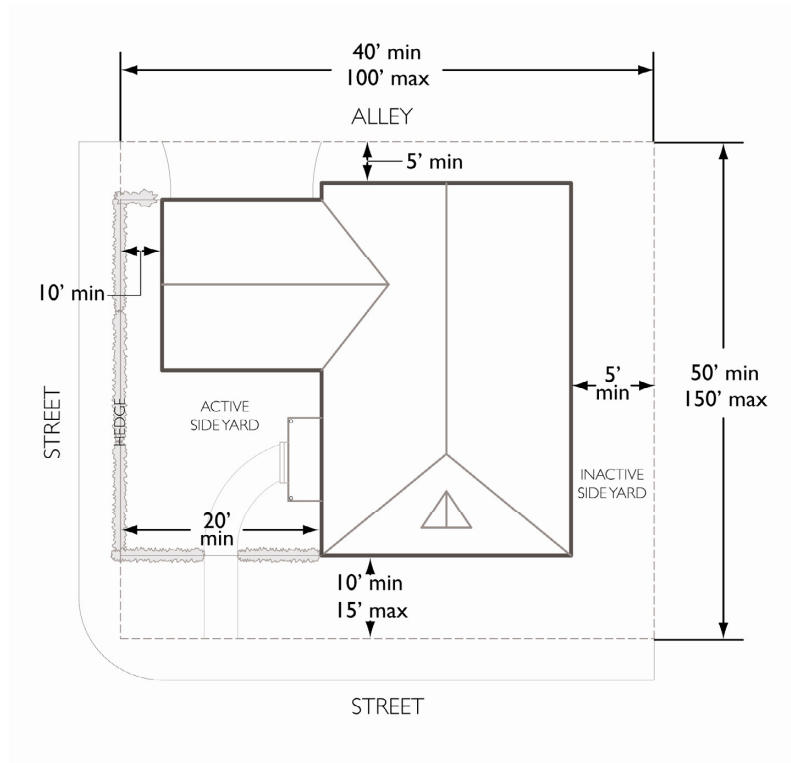

Figure 3 Side Yard House Standards

- c) **Setbacks and Height.** Side yard houses shall comply with the setback and height standards in Table 7 (Setback and Height Standards for Side Yard Houses).

TABLE 7 SETBACK AND HEIGHT STANDARDS FOR SIDE YARD HOUSES

	Min.	Max.
Setbacks		
Front	10 ft.	15 ft.
Inactive Side	5 ft.	-
Active Side	20 ft. for at least 50% of building facade; 10 ft. for remaining wall length	-
Street Side		-
Rear (abutting alley)	5 ft.	-
Height		30 ft.

- d) **Building Frontage.**
1. The building facade fronting the active side yard shall feature a porch.
 2. On a corner lot, the active side yard shall front the street.

- e) **Pedestrian and Vehicle Access.** The main entry to a side yard house shall be through either the building facade facing the active side yard or the front street-facing façade.

iii. **Cottage Home.**

- a) **Description.** A cottage home is an alley-loaded single dwelling unit on a small lot designed to be occupied by one household. Figure 4 (Cottage Home Standards) illustrates key development standards for cottage homes.

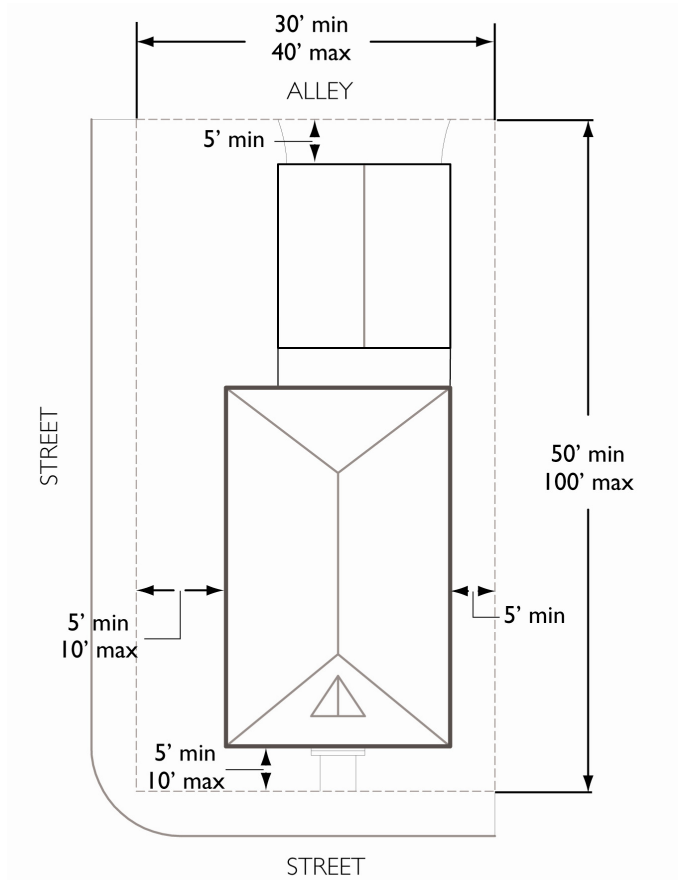

Figure 4 Cottage Home Standards

- b) **Lot Dimensions.** Lots occupied by cottage homes shall comply with the dimension standards in Table 8 (Lot Dimension Standards for Cottage Homes).

TABLE 8 LOT DIMENSION STANDARDS FOR COTTAGE HOMES

	Min.	Max.
Width	30 ft.	40 ft.
Depth	50 ft.	100 ft.

- c) **Setbacks and Height.** Cottage homes shall comply with the setback and height standards in Table 9 (Setback and Height Standards for Cottage Homes).

TABLE 9 SETBACK AND HEIGHT STANDARDS FOR COTTAGE HOMES

	Min.	Max.
Setbacks		
Front	5 ft.	10 ft.
Interior Side	5 ft.	-
Street Side	5 ft.	10 ft.
Rear (abutting alley)	5 ft.	-
Height		30 ft.

- d) **Vehicle Access.** Vehicle and service access to a cottage home is allowed only through an alley.

iv. **Bungalow Court.**

- a) **Description.** A bungalow court is a grouping of four or more detached dwelling units arranged around a central courtyard or open space. Figure 5 (Bungalow Court Standards) illustrates key development standards for bungalow courts.

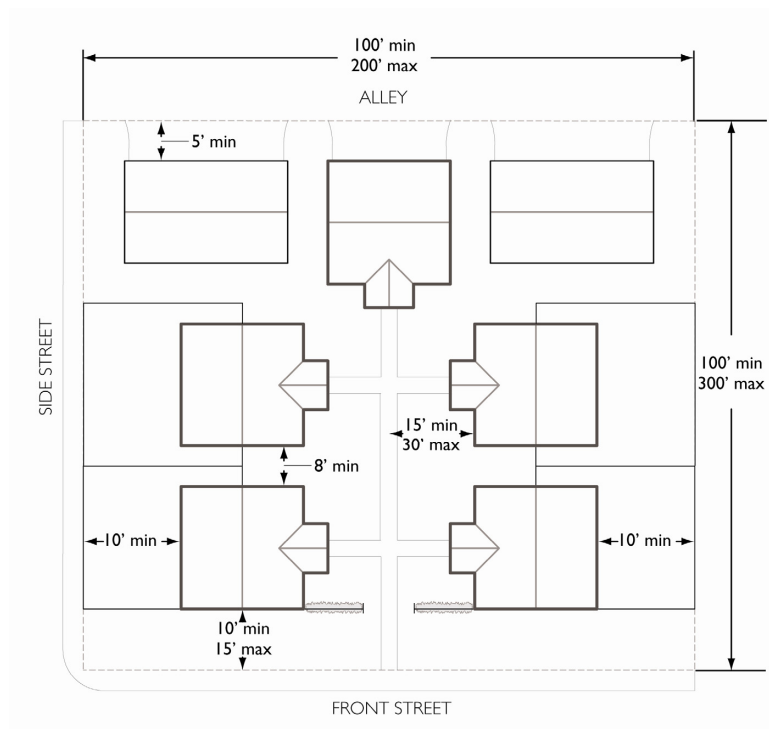

Figure 5 Bungalow Court Standards

- b) **Lot Dimensions.** Lots occupied by bungalow courts shall comply with the dimension standards in Table 10 (Lot Dimension Standards for Bungalow Courts).

TABLE 10 LOT DIMENSION STANDARDS FOR BUNGALOW COURTS

	Min.	Max.
Width	100 ft.	200 ft.
Depth	100 ft.	300 ft.

- c) **Setbacks and Height.** Bungalow Courts shall comply with the setback and height standards in Table 11 (Setback and Height Standards for Bungalow Courts).

TABLE 11 SETBACK AND HEIGHT STANDARDS FOR BUNGALOW COURTS

	Min.	Max.
Setbacks		
Between Structures on Lot	8 ft.	-
Front (street)	10 ft.	15 ft.
Front (courtyard)	15 ft.	30 ft.
Interior Side	10 ft.	-
Street Side	10 ft.	-
Rear	15 ft. [1]	-
Height		30 ft.

[1] The minimum rear setback shall be five feet when abutting an alley.

- d) **Pedestrian and Vehicle Access.**
1. The primary pedestrian entry to a bungalow court shall be provided from a public sidewalk adjacent to the central courtyard.
 2. The main entry to each unit shall face either the central courtyard or a public street.
 3. Vehicle and service access to the site shall be from a side street or alley. A side street is defined as the street abutting a side property line which does not provide primary pedestrian access to the site, as shown in Figure 5 (Bungalow Court Standards).
- e) **Central Courtyard.**
1. The central courtyard shall be a shared space accessible to all bungalow court residents.
 2. Pathways shall be provided from each unit to the central courtyard and from the central courtyard to a public sidewalk adjacent to the site.

3. The central courtyard shall be visible from the primary street frontage.
4. The amount of impervious surface in the central courtyard shall not exceed 50 percent of the total central courtyard area.

v. **Duplex.**

- a) **Description.** A duplex is a building containing two dwelling units. Dwelling units in a duplex shall be either stacked vertically (flats) or divided horizontally (townhouse-style). Figure 6 (Duplex Standards) illustrates key development standards for duplexes.

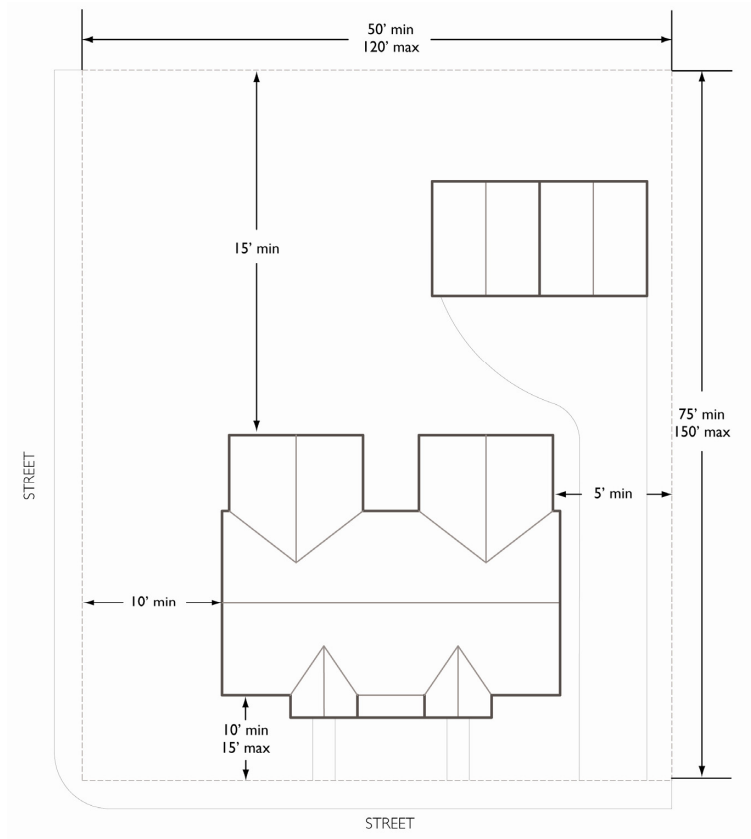

Figure 6 Duplex Standards

- b) **Lot Dimensions.** Lots occupied by duplexes shall comply with the dimension standards in Table 12 (Lot Dimension Standards for Duplexes).

TABLE 12 LOT DIMENSION STANDARDS FOR DUPLEXES

	Min.	Max.
Width	50 ft.	120 ft.
Depth	75 ft.	150 ft.

- c) **Setbacks and Height.** Duplexes shall comply with the setback and height standards in Table 13 (Setback and Height Standards for Duplexes).

TABLE 13 SETBACK AND HEIGHT STANDARDS FOR DUPLEXES

	Min.	Max.
Setbacks		
Front	10 ft.	15 ft.
Interior Side	5 ft.	-
Street Side	10 ft.	-
Rear	15 ft. [1]	-
Building Height		35 ft.

[1] The minimum rear setback shall be five feet when abutting an alley.

vi. **Mansion Apartment.**

- a) **Description.** A mansion apartment is a building containing three to eight dwelling units with the appearance from the street of a large house. Figure 7 (Mansion Apartment Standards) illustrates key development standards for a mansion apartment.

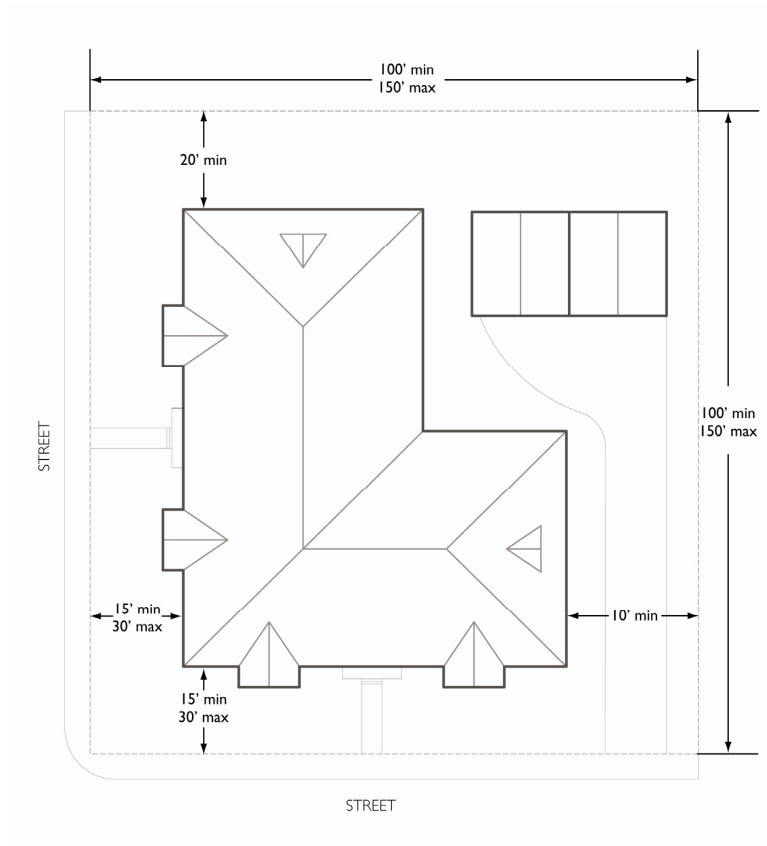

Figure 7 Mansion Apartment Standards

- b) **Lot Dimensions.** Lots occupied by a mansion apartment building shall comply with the dimension standards in Table 14 (Lot Dimension Standards for Mansion Apartment Buildings).

TABLE 14 LOT DIMENSION STANDARDS FOR MANSION APARTMENT BUILDINGS

	Min.	Max.
Width	100 ft.	150 ft.
Depth	100 ft.	150 ft.

- c) **Setbacks and Height.** Mansion apartment buildings shall comply with the setback and height standards in Table 15 (Setback and Height Standards for Mansion Apartment Buildings).

TABLE 15 SETBACK AND HEIGHT STANDARDS FOR MANSION APARTMENT BUILDINGS

	Min.	Max.
Setbacks		
Front	15 ft.	30 ft.
Interior Side	10 ft.	-
Street Side	15 ft.	30 ft.
Rear	20 ft. [1]	-
Height		35 ft.

[1] The minimum rear setback shall be five feet when abutting an alley.

- d) **Pedestrian Access.** The main pedestrian entry to all units in a mansion apartment building shall be provided from a central lobby within the building.

vii. **Side Court Apartment.**

- a) **Description.** A side court apartment building is a grouping of units arranged on a lot in a row with one unit facing the primary street and all other units facing an active side yard. Figure 8 (Side Court Apartment Standards) illustrates key development standards for a side court apartment building.
- b) **Lot Dimensions.** There are no lot dimension standards for a side court apartment building.

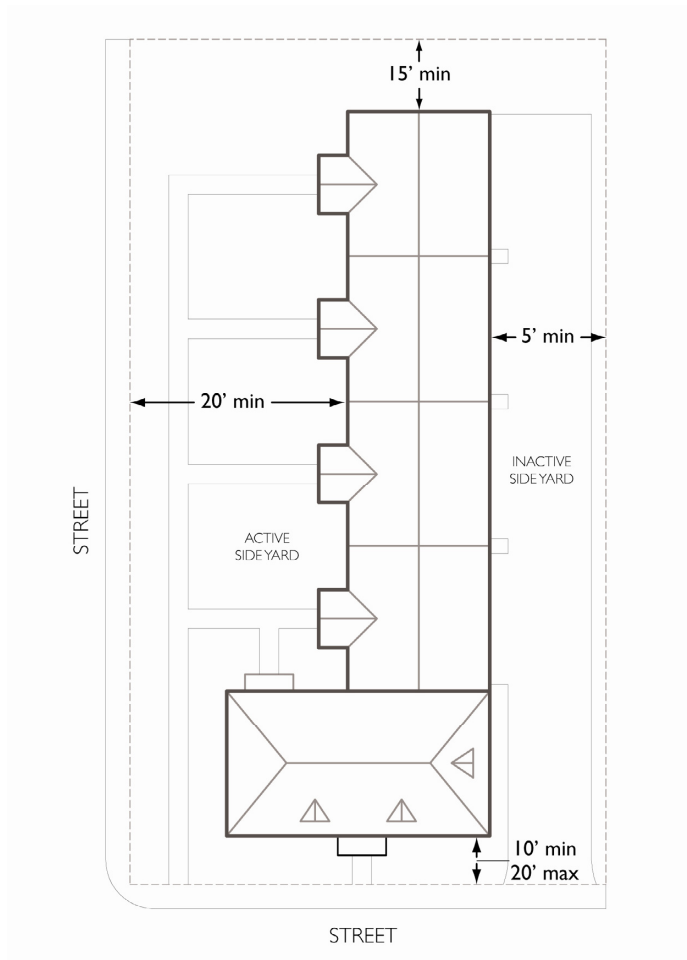

Figure 8 Side Court Apartment Standards

- c) **Setbacks and Height.** A side court apartment building shall comply with the setback and height standards in Table 16 (Setback and Height Standards for Side Court Apartment).

TABLE 16 SETBACK AND HEIGHT STANDARDS FOR SIDE COURT APARTMENT BUILDING

	Min.	Max.
Setbacks		
Front	10 ft.	20 ft.
Inactive side	5 ft.	-
Active Side	20 ft.	-
Street Side	20 ft.	-
Rear	15 ft. [1]	-
Height		35 ft.

[1] The minimum rear setback shall be five feet when abutting an alley.

- d) **Building Frontage.** On a corner lot, the active side yard shall front the street.
- e) **Pedestrian Access.** The main entry to the unit fronting the primary street shall be through the front street-facing façade. The main entry for all other units shall be through the active side yard.
- f) **Active Side Yard.**
 1. The active side yard shall be a shared space accessible to all side court apartment residents.
 2. Pathways shall be provided from each unit to the active side yard and from the active side yard to public sidewalks adjacent to the site.
 3. The amount of impervious surface in the active side yard shall not exceed 50 percent of the total side yard area.
 4. The active side yard shall be at least 20 feet in width.

viii. **Courtyard Apartment.**

- a) **Description.** A courtyard apartment building is a grouping of attached dwelling units arranged to share one or more central courtyards. Figure 9 (Courtyard Apartment Standards) illustrates key development standards for a courtyard apartment.

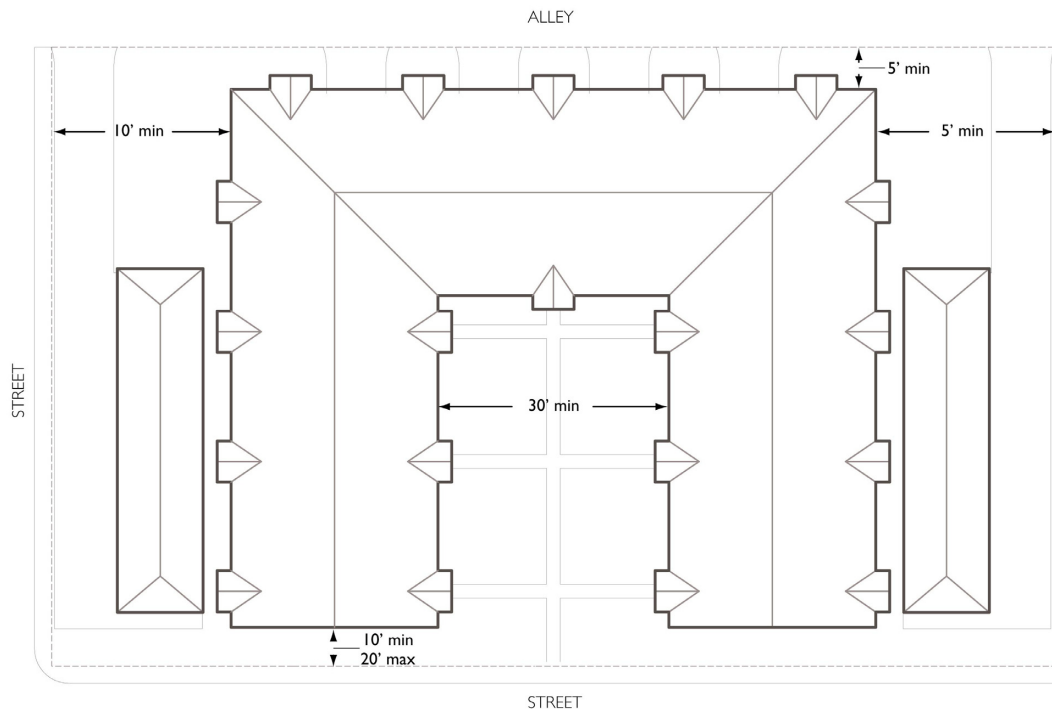

Figure 9 Courtyard Apartment Standards

- b) **Lot Dimensions.** There are no lot dimension standards for a courtyard apartment building.
- c) **Setbacks and Height.** Courtyard apartment buildings shall comply with the setback and height standards in Table 17 (Setback and Height Standards for Courtyard Apartment Buildings).

TABLE 17 SETBACK AND HEIGHT STANDARDS FOR COURTYARD APARTMENT BUILDINGS

	Min.	Max.
Setbacks		
Front	10 ft.	20 ft.
Interior Side	5 ft.	-
Street Side	10 ft.	-
Rear	15 ft. [1]	-
Height		35 ft.

[1] The minimum rear setback shall be five feet when abutting an alley.

- d) **Pedestrian Access.** The primary entry to individual units or the interior lobby of a courtyard apartment building shall be through the central courtyard.
- e) **Central Courtyard.**
 1. The central courtyard shall be a shared space accessible to all building residents.
 2. Pathways shall be provided from each unit to the central courtyard and from the central courtyard to a public sidewalk adjacent to the site.
 3. The central courtyard shall be visible from the primary street frontage.
 4. The amount of impervious surface in central courtyard shall not exceed 50 percent of the total courtyard area.
 5. The central courtyard shall be at least 30 feet in width.

ix. **Townhouse.**

- a) **Description.** A townhouse is a grouping of attached alley-loaded single dwelling units each with its own separate street entrance. Figure 10 (Townhouse Standards) illustrates key development standards for townhouses.
- b) **Lot Dimensions.** There are no lot dimension standards for townhouses.
- c) **Setbacks and Height.** Townhouses shall comply with the setback and height standards in Table 18 (Setback and Height Standards for Townhouses).

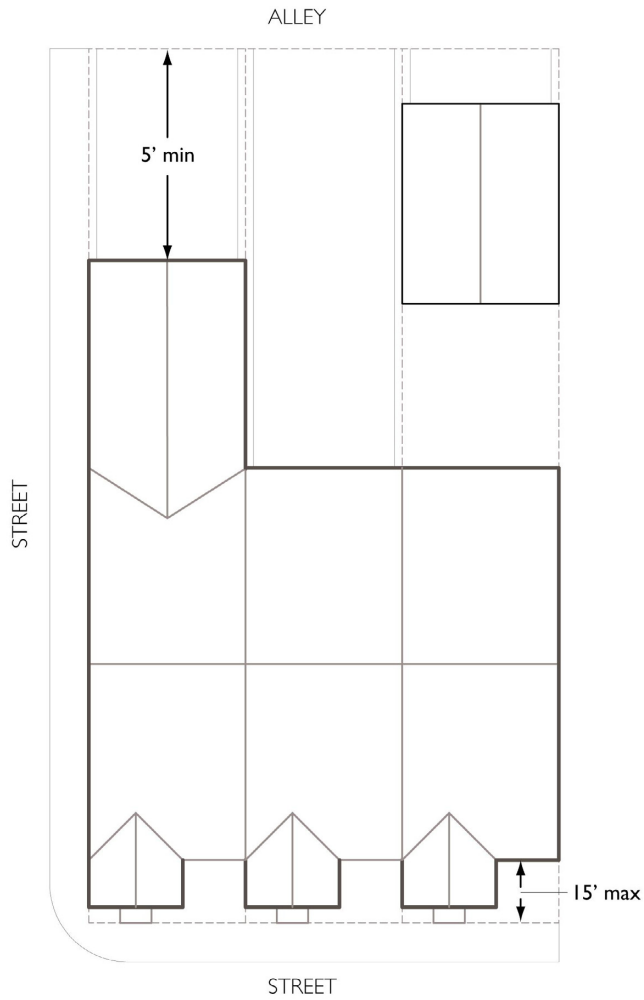

Figure 10 Townhouse Standards

TABLE 18 SETBACK AND HEIGHT STANDARDS FOR TOWNHOUSES

	Min.	Max.
Setbacks		
Front	-	15 ft.
Interior Side	-	0 ft.
Street Side	-	15 ft.
Rear (abutting alley)	5 ft.	-
Height		35 ft.

- d) **Vehicle Access.** Vehicle and service access to a townhouse is allowed only through an alley.

x. **Stacked Dwelling.**

- a) **Description.** A stacked dwelling is a residential building containing three or more dwelling units that are accessed from a common entrance and lobby. Figure 11 (Stacked Dwelling Standards) illustrates key development standards for stacked dwellings.

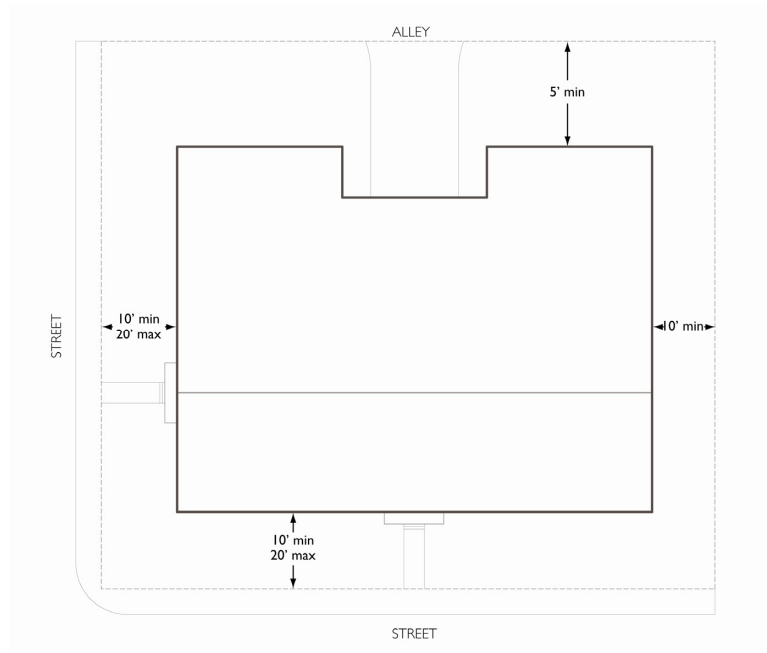

Figure 11 Stacked Dwelling Standards

- b) **Lot Dimensions.** There are no lot dimension requirements for stacked dwellings.
- c) **Setbacks and Height.** Stacked dwellings shall comply with the setback and height standards in Table 19 (Setback and Height Standards for Stacked Dwellings).

TABLE 19 SETBACK AND HEIGHT STANDARDS FOR STACKED DWELLINGS

	Min.	Max.
Setbacks		
Front	10 ft.	20 ft.
Interior Side	10 ft.	-
Street Side	10 ft.	20 ft.
Rear	15 ft. [1]	-
Height		40 ft.

[1] The minimum rear setback shall be five feet when abutting an alley.

- d) **Pedestrian Access.** Primary pedestrian access to units within a stacked dwelling building shall be provided through a lobby fronting a public street.

6. Frontage Types.

- a. **Frontage Types Defined.** Frontage types refer to the design and function of exterior front building facades. Frontage types define the way a structure engages the street and provides a transition between the public and private realm.
- b. **Allowable Frontage Types by Zone.** Frontage types permitted for each building type shall be as shown in Table 20 (Permitted Frontage Types).

TABLE 20 PERMITTED FRONTAGE TYPES

	Porch	Stoop	Forecourt
Detached Home	P	P	-
Side Yard House	P	P	-
Cottage Home	P	P	-
Bungalow Court	P	P	-
Duplex	P	P	-
Mansion Apartment	P	P	-
Central Courtyard Apartment	-	P	P
Side Court Apartment	P	P	-
Courtyard Apartment	-	P	P
Townhouse	P	P	-
Stacked Dwelling	-	P	P

- c. **Unlisted Frontage Types.** To promote creativity and innovation in the design of new neighborhoods, the City may permit frontage types other than those listed in Table 20 when the frontage type is consistent with the desired design character of the zone, the frontage type expands the diversity of frontage type choices and architectural variety and appeal within the neighborhood.
- d. **Projections into Setback Areas.**
 - i. Porches, stoops and dooryard frontage types may project up to six feet into required front setback areas. Under no circumstance shall railings, columns, eaves, or any other improvements or projections of a building’s frontage extend across property lines into the public right-of-way or neighboring properties.
 - ii. For building types with a central courtyard or active side yard, porches and stoops may project up to six feet into required courtyard or active side yard setback area.
- e. **Frontage Type Standards.** This section establishes standards for each frontage type.

- i. **Porch.** A porch is a covered but unenclosed projection from the outside wall of a building, generally surrounding the main entry to the building. A porch is of sufficient size to allow for use as an outdoor sitting and gathering area.
 - a) Porches shall feature a minimum depth of 8 feet, a minimum width of 12 feet and a minimum height of 10 feet.
 - b) The maximum elevation of a porch shall be 4 feet from adjacent grade.
 - c) A maximum railing height for a porch shall be 3.5 feet; the enclosure of porch sides is prohibited.
- ii. **Stoop.** A stoop is an unenclosed elevated platform projecting from the front or side outside wall of a building providing access to the ground level of the building.
 - a) Stoops shall feature a minimum depth of 2 feet and a minimum width of 3 feet.
 - b) The maximum elevation of a stoop shall be 4 feet from adjacent sidewalk grade.
 - c) A maximum railing height for a stoop shall be 3.5 feet; the enclosure of stoop sides is prohibited.
- iii. **Forecourt.** A forecourt is a recessed portion of a front building facade providing an open area partially surrounded by building walls that opens to an adjacent public sidewalk.
 - a) Forecourts shall feature a minimum depth of 6 feet, a minimum width of 20 feet and a maximum width of 40 feet.
 - b) The maximum elevation of the internal area of a forecourt shall be 4 feet from adjacent grade.